



PREMIUM FUEL REQUIRED

2010+ 6.2L Camaro Supercharger Kit

P/N: 92000A (HH-6006)

Installation Instructions



Application:

2010+ Chevrolet Camaro equipped with a 6.2L Engine (Manual & Automatic Transmission)

Important Notes:

- STOP - DO NOT BEGIN THE INSTALLATION OF THIS SUPERCHARGER KIT WITH OUT FOLLOWING THE INSTRUCTIONS FOR DOWNLOADING THE FACTORY VEHICLE CALIBRATION FILE AND E-MAILING IT TO SLP. FAILURE TO DO THIS PRIOR TO DISMANTLING THE VEHICLE MAY CAUSE A DELAY IN THE ASSEMBLY OF THIS KIT.**
- Before installing your SLP Camaro Supercharger Kit, please read the installation manual and verify that all items are present. If you are missing hardware or have any questions, please contact SLP Performance at 1-855-SLP-PERF (1-800-757-7373).
- Premium fuel (91 octane or higher) is REQUIRED to prevent “spark-knock” or detonation under certain operating conditions.**
- Operating your engine without the SLP PCM recalibration will result in engine damage or failure and will void your warranty.
- The use of fuel additives (ie. octane boosters) is not recommended. There is a possibility that these chemicals can damage your engine and cause drivability issues with your vehicle.
- 2010 – 2011 Vehicles require the separate purchase of GM Heater Hose Part Number: 22962570 Heater Hose Asy to complete the installation. (NOT INCLUDED with this kit)**
- If the vehicle being equipped with the SLP supercharger kit is an automatic, please check your DOD plate as shown on the next page PRIOR to beginning the kit installation. Failure to do so will result in a delay of your build.**
- Vehicles equipped with the optional 1LE package will require the removal & relocation of the oil separator on the passenger rocker cover.**



PREMIUM FUEL REQUIRED

ATTENTION - IMPORTANT NOTE FOR VEHICLES EQUIPPED WITH AN AUTOMATIC TRANSMISSION (L99). CHECK THIS PRIOR TO INSTALLING SUPERCHARGER KIT TO AVOID DELAYS.

IF YOUR CAR IS EQUIPPED WITH AN AUTOMATIC TRANSMISSION, PLEASE CONFIRM WHICH DISPLACEMENT ON DEMAND (DOD) PLATE YOUR VEHICLE WAS BUILT WITH. THIS CAN ONLY BE DONE BY REMOVING THE INTAKE MANIFOLD ASSEMBLY AND LOOKING IN THE ENGINE VALLEY. THE PLATE ON THE LEFT – SLP P/N 620053, GM P/N 12571609 IS THE PLATE THAT WORKS WITH THE SLP SC KIT. IF YOU HAVE THE PLATE ON THE RIGHT (WITH THE RAISED SURFACES HIGHLIGHTED), YOU WILL NEED TO ORDER THE OTHER PLATE. PLEASE CALL 1-855-SLP-PERF (1-855-757-7377) OR YOUR LOCAL CHEVY DEALER TO OBTAIN A NEW PLATE.



The plate shown on the right has large bosses as circled. If you have this plate on your L99 Automatic Camaro you will need to replace the component to complete the installation. Refer to Appendix A at the end of this manual.



PREMIUM FUEL REQUIRED

VEHICLE CALIBRATION INFORMATION (THIS INFO NOT APPLICABLE TO THE TUNER KITS)

THIS KIT WAS SHIPPED WITH AN UNPROGRAMMED INTUNE HAND HELD PROGRAMMING DEVICE (SLP-1010). PRIOR TO BEGINNING THE INSTALLATION OF THIS KIT, PLEASE PROCEED WITH THE FOLLOWING STEPS. THIS SHOULD BE DONE IN ADVANCE OF ANY VEHICLE DISASSEMBLY TO AVOID DELAYS DURING YOUR INSTALLATION. CALIBRATION SUPPORT IS PROVIDED MONDAY – FRIDAY 8 AM TO 5 PM EST.

OBTAINING YOUR FACTORY CALIBRATION

- 1) Plug the “inTune” programmer (SLP-1010) into the OBD port of the vehicle the supercharger kit will be installed into.
- 2) Select “Tune Vehicle” from the menu screen. Touch “Yes” to accept the terms of usage.

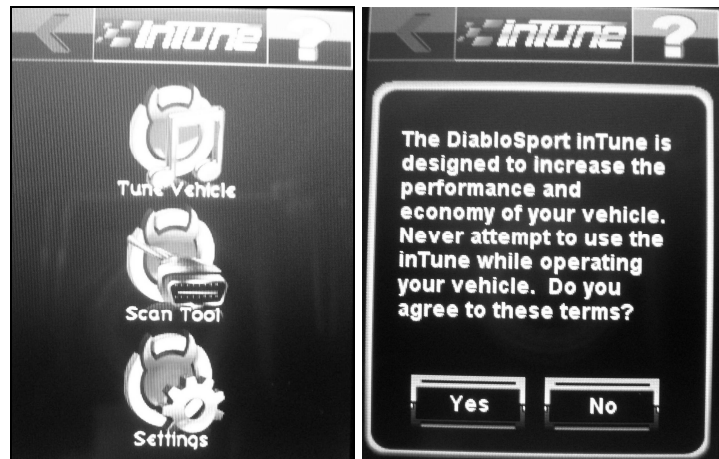

- 3) Select “Write Vehicle” from the menu screen. When prompted, turn the ignition to the key on position. DO NOT START the engine.

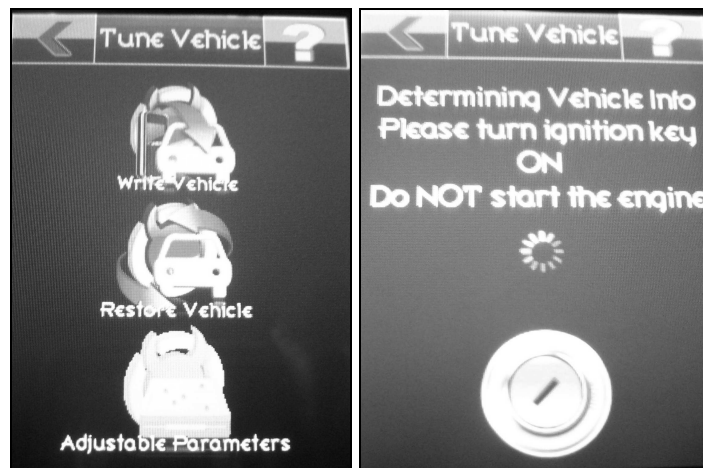



PREMIUM FUEL REQUIRED

- 4) Your vehicle VIN will be shown along the top of the screen. Select "Read Backup" from the menu screen.

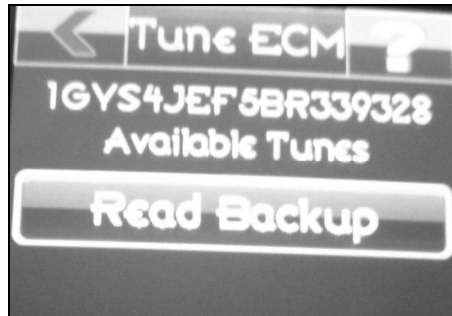

- 5) Select the Green Check Mark to allow the device to read and create backup files of both the Engine Control Module (ECM) and the Transmission Control Module (TCM). Select Continue when prompted after each file is created.

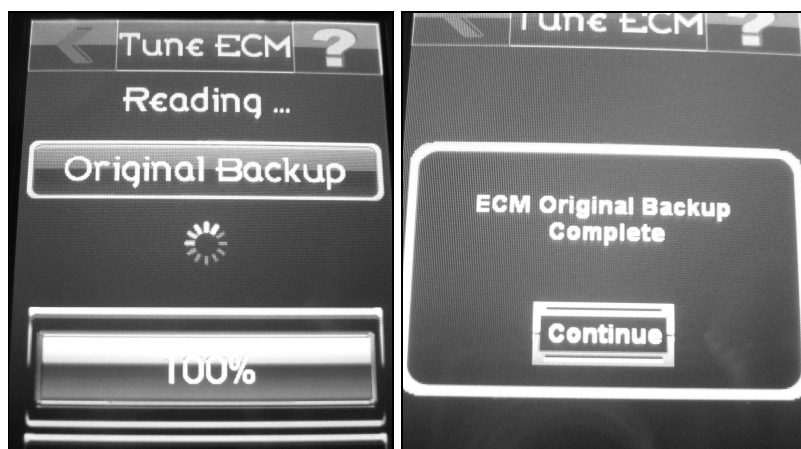
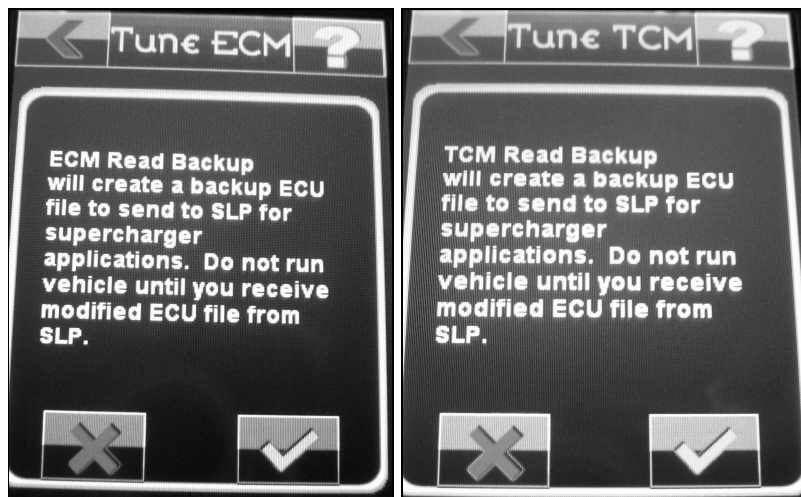



PREMIUM FUEL REQUIRED

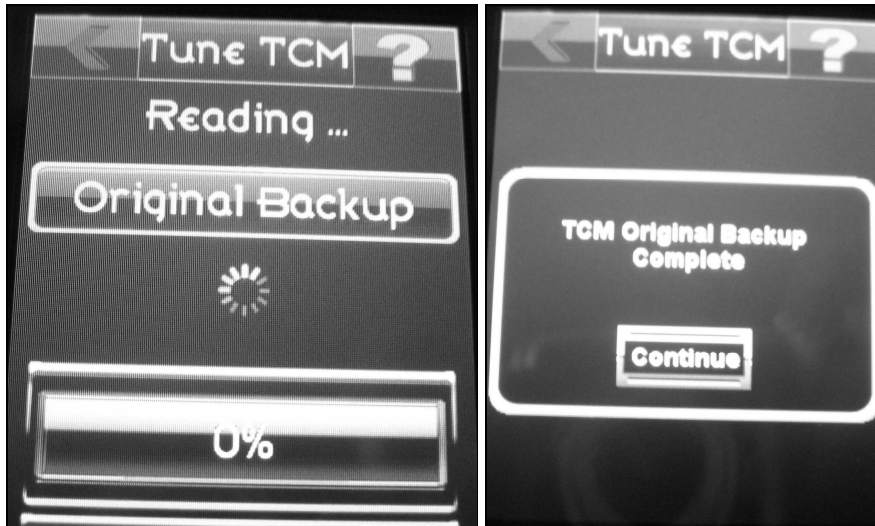

- 6) When prompted to install the ECM Read Backup and TCM Read Backup, select the RED X. The device should now read ECM/TCM Unchanged, select Continue, unplug the device from the car, and turn off the ignition.

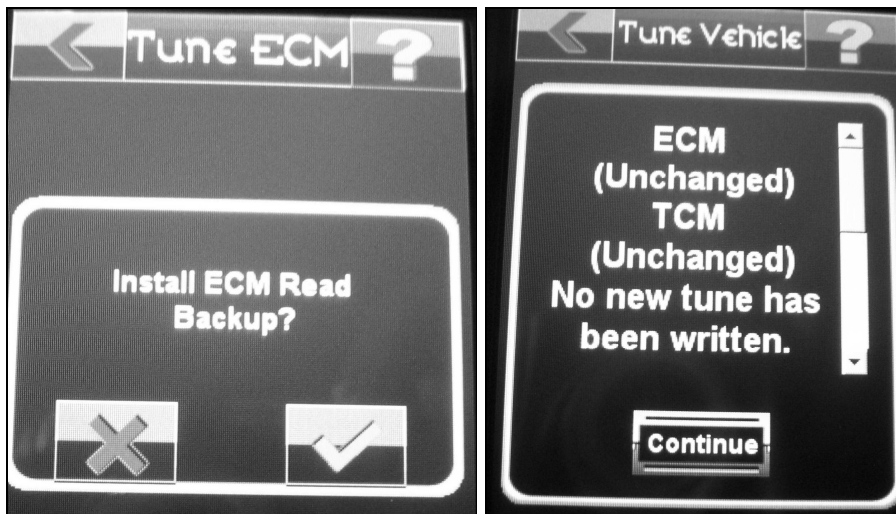

- 7) The factory calibration files are now loaded on the device. Plug the device into a PC using the supplied mini-USB to USB cord, found in the box.



PREMIUM FUEL REQUIRED

- 8) Open the device like a digital camera would be opened, by going to “My Computer” and click on the icon for the port to which the device is plugged into.

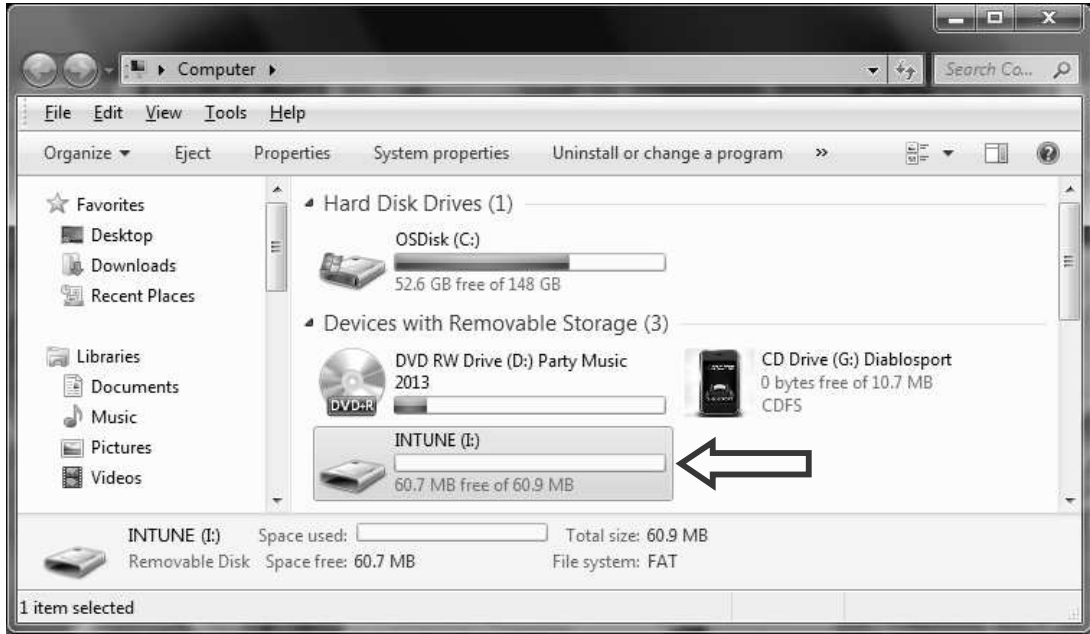

- 9) Open the folder labeled “tunes”.

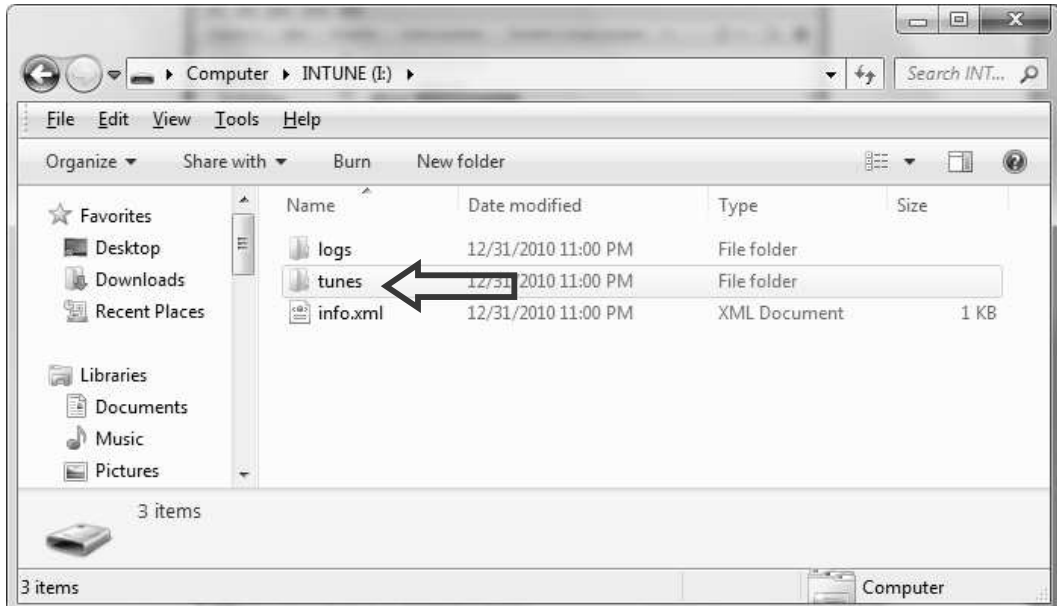



PREMIUM FUEL REQUIRED

- 10) In this folder you will see two files listed. This is a copy of your vehicles factory calibration (One for the Engine Control Module and one for the Transmission Control Module). Add the text “backup” to the file name if it is not present already and e-mail a copy of these files to “tune@slponline.com” .

In the e-mail subject line write: **Calibration Request for Kit # 92025A**

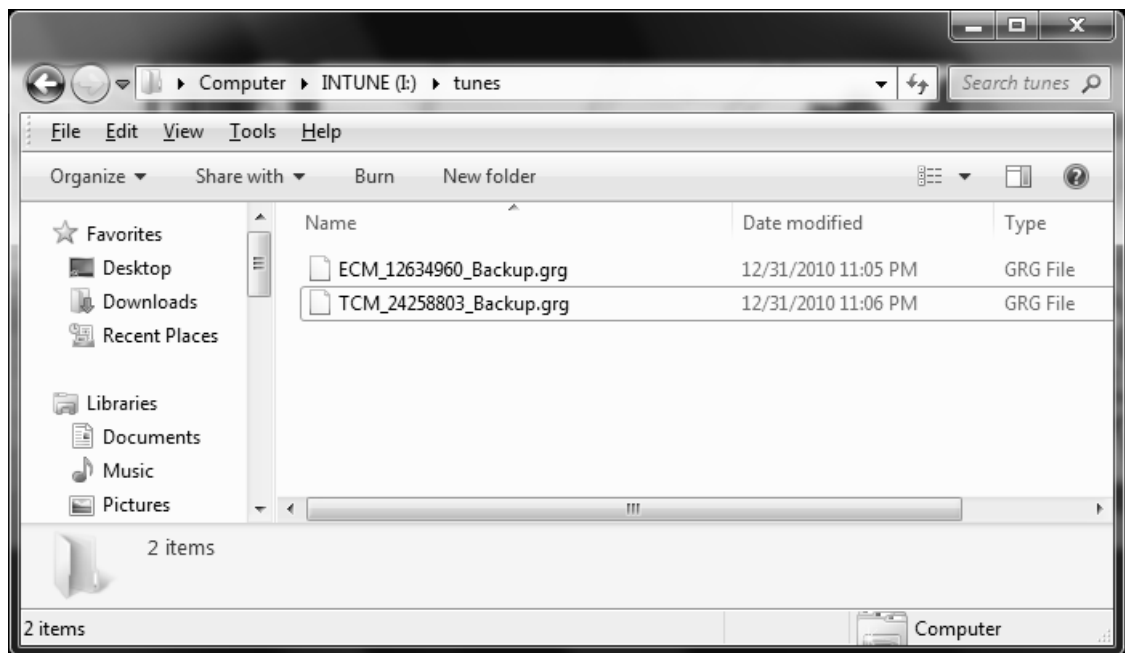

- 11) SLP will reply to your e-mail within one business day (Monday to Friday, 8 am to 5 pm EST) with the supercharger calibration file for your vehicle.

FAILURE TO FOLLOW THE ABOVE STEPS MAY DELAY THE INSTALLATION OF THIS KIT. SLP NEEDS THIS DATA IN ORDER TO PROVIDE YOU WITH THE LATEST CALIBRATION FILES AVAILABLE FOR YOUR VEHICLE. IF YOU HAVE A NEW MODEL YEAR VEHICLE THAT IS NOT YET AVAILABLE IN OUR DATABASE, THE TURN AROUND TIME FOR THE CALIBRATION MAY EXCEED 1 BUSINESS DAY. IF THE CALIBRATION IS NOT YET SUPPORTED, SLP WILL NOTIFY YOU OF THIS DELAY AS TO NOT CAUSE YOUR VEHICLE FROM BEING IMMOBILIZED DURING THIS TIME.

- 12) Save a copy of the file attached to the e-mail sent back from SLP to the desktop of your PC. This is your new calibration file.
- 13) Plug the “inTune” device into your PC.



PREMIUM FUEL REQUIRED

- 14) Drag and drop the new calibration file directly into the main inTune folder that opens. DO NOT drag into the folder labeled “tunes”. If no folder opens, double click My Computer on your desktop and select the inTune device. Place the new file into the main folder here.

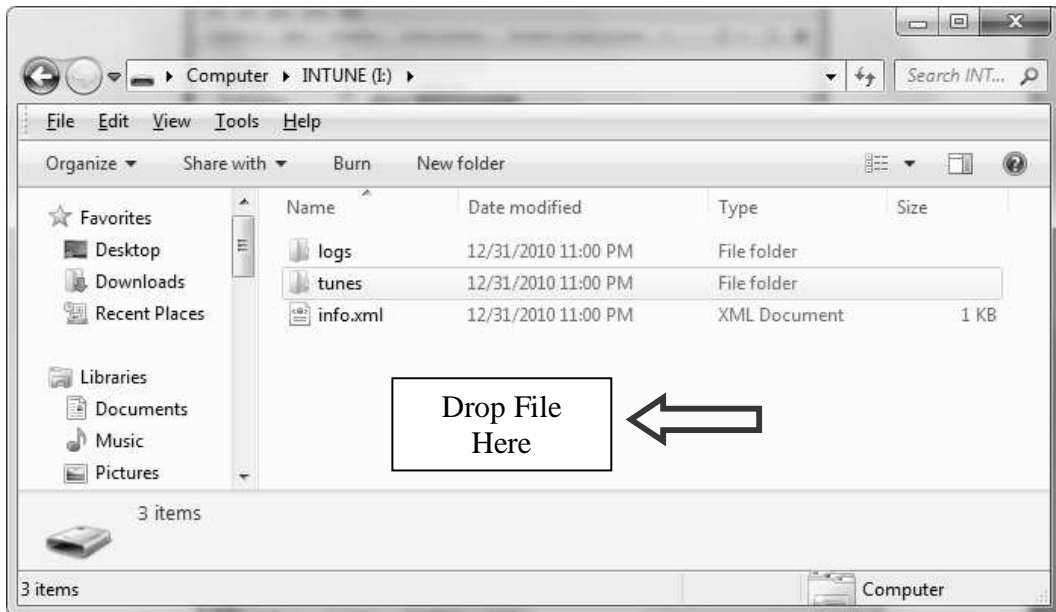

- 15) Your device is now ready to reprogram the vehicle. You can now begin the installation of the supercharger kit on your vehicle.



PREMIUM FUEL REQUIRED

TABLE OF CONTENTS

Packing List.....	10
Equipment and Supplies Required.....	13
Glossary of Terms.....	14
INFORMATION ABOUT THE SUPERCHARGER BYPASS OPERATION	14
LIMIT OF LIABILITY STATEMENT	15
SAFETY PRECAUTIONS	15
SECTION A – DISASSEMBLY	16
SECTION B – MODIFICATIONS	23
Throttle Body Removal	23
EVAP Solenoid Bracket Modification & Relocation.....	23
SECTION C – SUBASSEMBLY	26
Intercooler Low Temperature Radiator (LTR)	26
EVAP Hose Assembly	28
Intake Manifold Build Up.....	28
Degas Bottle Mounting Bracket	28
Intercooler Pump Wiring Harness.....	28
SECTION D – INSTALLATION	34
Intake Manifold and Supercharger.....	34
FEAD Assembly	40
Wiring	42
Intercooler Pump Mounting.....	43
Intercooler Radiator Assembly Mounting	47
Intercooler Degas Bottle Mounting	49
Intercooler Hose Routing.....	51
Air Induction System.....	54
Vehicle Reprogramming	57
Final Assembly	63
APPENDIX A	65



PREMIUM FUEL REQUIRED

PACKAGING LIST FOR ITEM 92000A
(HH-6006) SUPERCHARGER KIT

Part Ref	Description	Part Number	Qty
	Air Induction	---	
1	Clean Air Tube	210125212	1
2	Coupler Sleeve – Clean Air Tube to Throttle Body	25180042	1
3	Bellows Coupler – Clean Air Tube to Airbox	100064010	1
4	Clamps – Clean Air Tube Coupler	210144126	2

Part Ref	Description	Part Number	Qty
5	Fuel Charging Assembly	HH-9H487	1
6	SLP TVS2300 Supercharger Assembly	HH-6F066	1
7	Fuel Rail	HH-9F792	1
8	Fuel Supply Line Jumper	HH-9E964	1

Part Ref	Description	Part Number	Qty
	Hardware Kit A – Fuel Charging	HH-HWKA	1
9	Bolts- Throttle body to S/C Inlet: M6 x 1.00 x 40	R18020004	4
10	Fuel Injectors (56 #/HR @ 4 Bar)	0280158187	8
11	Gasket - S/C to Upper	R07060166	1
12	Gasket - Supercharger Bypass	R07060183	1
13	Gasket Set – Intake to Cylinder Head (pkg of 8)	19256623	1
14	Bolts - S/C to Intake (M8 x 1..25 x 53)	N808130	8
15	Bolts - Fuel Charging to Cylinder Head (M6 x 1.0 x 74.5)	N807072	10
16	Bolts - Fuel Rail (M6x1.0 x32.5)	R18020009	4
17	Bolt - TMAP to Upper Intake (M6x1x16)	W500213	1
18	TMAP Sensor	90423637	1
19	Badge – SLP (Front of Supercharger)	010036203	1
20	Badge - TVS2300 (Top of Supercharger)	010036202	1
21	Bolt – M4x16 (Badge Mounting)	940706400	4

Part Ref	Description	Part Number	Qty
	FEAD	---	
22	Idler Mounting Bracket	HH-8B653	1
23	Tensioner Assembly	12569301	1
24	Supercharger Pulley – 6K 98mm	HH-6K98	1
25	Serpentine FEAD Belt (2010 – 2012 Model Years) (K061037)	904068124	1
26	Serpentine FEAD Belt (2013 – 2014 Model Years) (K061000)	904068125	1



PREMIUM FUEL REQUIRED

Part Ref	Description	Part Number	Qty
	Hardware Kit B – FEAD	HH-HWKB	1
27	Idler - B/S Non-Flanged	08567-32	1
28	Bolt- S/C Pulley (M6X1.0X16)	W500013	5
29	Bolt - Idler to FEAD Bracket (M8 x 1.25 x 28)	R18020060	1
30	Bolt - Idler Brkt to Engine (M8 x 1.25 x 95)	HHCS8X1.25X95	2
31	Bolt - Idler Brkt to Engine (M8 x 1.25 x 130)	HHCS8X1.25X130	1
32	Washer - M8 2MM Thick	M82MM	3

Part Ref	Description	Part Number	Qty
	Hardware Kit C - Wiring	HH-HWKC	1
33	Electrical Jumper – Intercooler Pump	HH-8W501	1
34	TMAP / MAF Wiring Harness	HH-12A690	1
35	Fuse Connector	R18060010	1
36	10 Amp Fuse	08N2483	1
37	Self Tapping Fastener for Relay	R07030003	1

Part Ref	Description	Part Number	Qty
	Hardware Kit D - PCV & Vacuum	HH-HWKD	1
38	3/8" Hose SAE30R7 w/Clamps - PCV Fresh Air Inlet - 350mm	HH-6758	1
39	3/8" Hose SAE30R7 w/Clamps- PCV Purge Tube - 520mm	HH-6K817	1
40	5/16" Hose SAE30R7 w/Clamps - VMV to S/C - 335mm	HH-9G297	1
41	1/2" Hose SAEJ1403 - Brake Booster - 710mm	HH-2B432	1
42	Constant Tension Clamp – Brake Booster Hose 1/2"	2UTG7	2
43	7/32" Vacuum Harness - S/C Bypass - 191mm	R18140001	1

Part Ref	Description	Part Number	Qty
	Intercooler System	---	
44	Degas Bottle	R07070007	1
45	Degas Bottle Mounting Bracket (2010 – 2011 Model Years)	HH2010-6B634	1
46	Degas Bottle Mounting Bracket (2012+ Model Years)	HH-6B634	1
47	Intercooler Electric Water Pump	F8YZ-8501	1
48	Intercooler Low Temp Radiator (LTR)	HH-8K229	1

Part Ref	Description	Part Number	Qty
	Hardware Kit E – Intercooler Hoses	HH-HWKE	1
49	Degas to I/C Pump - 3/4" hose x 435mm (17.125")	HH-8D029	1
50	I/C Pump to LTR - 3/4" hose x 622 mm(24.5")	HH-8K236	1
51	LTR to CAC - 3/4" hose x 1524mm (60")	HH-8D030	1
52	CAC to Degas - 3/4" hose x 800mm (31.5")	HH-8D031	1
53	Clamps - 3/4" Constant Tension	CT19X12-BO	8



PREMIUM FUEL REQUIRED

Part Ref	Description	Part Number	Qty
	Hardware Kit F – Intercooler System	HH-HWKF	1
54	I/C Pump Mounting- P-Clip 2.25" I.D. x 3/4" Wide	F523-036CA	1
55	Bolt - I/C Pump Mounting (Self Tapping M8x1.25x27)	N802455	1
56	Cap - Degas Bottle	9C3Z-8101	1
57	Nut - M6x1.0 (Degas Bottle to Mounting Bracket)	W520412	2
58	J-Clip - Degas Bottle Mounting Bracket to Fan Shroud (M6x1.0)	N623332	1
59	Bolt - Degas Bottle Mounting Bracket to Fan Shroud (M6x1.0x14)	N605771	1
60	PLUG - 1/8" NPT	W706310	1
61	Foam Tape- 25.4MM x 4.763MM x 65MM	HH-8K231	2
62	Foam Tape: 25.4MM x 12.7MM x 570MM	HH-8K232	2
63	Foam Tape: 25.4MM x 12.7MM x 35MM	HH-8K233	1

Part Ref	Description	Part Number	Qty
	Hardware Kit G - Decals / Labels & Instructions	HH-HWKG	1
64	Decal – Belt Routing Diagram (2010 – 2012)	HH-6E072	1
65	Decal – Belt Routing Diagram (2013+)	HH13-6E072	1
66	Decal – Premium Fuel Only	0102040127	1
67	Decal - EO	HH09-9A095EO	1
68	OBD Cover	12146933	1
69	Decal – Do Not Flash (OBD Cover)	HH-OBDCV	1
70	InTune Handheld Programmer	SLP-1010	1
71	Installation Manual	HH-6006IM	1

If you are missing any items, please call us toll free at 1-855-SLP-PERF.



PREMIUM FUEL REQUIRED

EQUIPMENT AND SUPPLIES REQUIRED

- 1/4" and 3/8" Drive Ratchets with Extensions
- Metric and Standard Socket Sets (short and deep recommended)
- 1/2" Drive Ratchet or Breaker Bar
- Metric and Standard Wrench Sets
- 3/8" Drive Torque Wrench (7-35 ft-lb range)
- Short Phillips-head Screwdriver
- 5/8" Fuel Line Removal Tool
- T-20 Torx Bit Screwdriver or Socket
- 3" Hole saw & Drill motor or Air Saw
- Coolant (meeting Factory GM specification for 2010+ Camaro)
- 6" Scale, Tape Measure, or Other Measuring Device
- Assembly Lubricant (White Lithium Grease or Petroleum Jelly)
- Electrical Tape
- Sharp Knife or Razor Blade
- Solder & Soldering Iron
- Heat Gun or Small Torch for Heat Shrink Tubing
- Tie Straps (Zip Ties)
- Trim Pad Tool (for pushpin removal)
- Fender Cover (2)
- Medium Strength Thread Locker - Loctite 242 (Blue) or equivalent



PREMIUM FUEL REQUIRED

GLOSSARY OF TERMS

MAP	Manifold Absolute Pressure Sensor
ETC	Electronic Throttle Control
MAFS	Mass Air Flow Sensor
PCM	Powertrain Control Module (a.k.a. ECM, ECU, PCU, EEC)
PCV	Positive Crankcase Ventilation
TPS	Throttle Position Sensor
VMV	Vapor Management Valve (aka Canister Purge Valve)
Breakout Point	A place in an electrical harness where the wiring for an individual component leaves (breaks out of) the main harness to attach to an individual component.

INFORMATION ABOUT THE SUPERCHARGER BYPASS OPERATION

There is a great deal of misinformation about the function of supercharger bypass systems. The supercharger is a positive-displacement pump; that is, so long as it is rotating, it is always pumping air. During low demand or high vacuum operation (i.e. idle, deceleration, and light throttle cruise), the pumping action is undesirable as it creates unwanted heat and noise. The bypass circuit, when open, prevents any pressure buildup across the supercharger and allows air to circulate through the rotors, allowing the supercharger to "idle" freely during these conditions. This results in reduced noise, and by reducing heat buildup in the intake, significantly improves street and strip performance. As throttle demand increases, the bypass circuit is closed, resulting in full performance from the supercharger. The bypass circuit is never used to limit or control boost during full-throttle operation and defeating or altering the bypass function will not result in improved performance in any condition, and will result in poor drivability.



PREMIUM FUEL REQUIRED

LIMIT OF LIABILITY STATEMENT

The information contained in this publication was accurate and in effect at the time the publication was approved for printing and is subject to change without notice or liability. SLP Performance Parts reserves the right to revise the information presented herein or to discontinue the production of parts described at any time.

SAFETY PRECAUTIONS

STOP! CAREFULLY READ THE IMPORTANT SAFETY PRECAUTIONS AND WARNINGS BEFORE PROCEEDING WITH THE INSTALLATION!

Appropriate disassembly, assembly methods and procedures are essential to ensure the personal safety of the individual performing the kit installation. Improper installation due to the failure to correctly follow these instructions could cause personal injury or death. Read each step of the installation manual carefully before starting the installation.

- ! Always wear safety glasses for eye protection.
- ! Place the ignition switch in the OFF position.
- ! Always apply the parking brake when working on the vehicle.
- ! Block the front and rear tire surfaces to prevent unexpected vehicle movement.
- ! Operate the engine only in well-ventilated areas to avoid exposure to carbon monoxide.
- ! Do not smoke or use flammable items near or around the fuel system.
- ! Use chemicals and cleaners only in well-ventilated areas.
- ! Batteries can produce explosive hydrogen gas which can cause personal injury. Do not allow flames, sparks or flammable sources to come near the battery.
- ! Keep hands and any other objects away from the radiator fan blades.
- ! Keep yourself and your clothing away from moving parts when the engine is running.
- ! Do not wear loose clothing or jewelry that can be caught in rotating or moving parts.
- ! Disconnect both the Negative (-) and Positive (+) Battery Terminal Leads (in this order) to reduce the risk of electric shock.



PREMIUM FUEL REQUIRED

SECTION A – DISASSEMBLY

The following section will guide you through the disassembly of the stock components. Special care should be taken to label fasteners and parts that are taken off during this procedure since some will be reused:

1. Plug the inTune device (SLP-1010) into the OBD port and follow pages 3 - 8 of this manual.
2. Cover both fenders with fender covers to protect the vehicle finish.
3. Remove the engine beauty cover. Set this aside as it will not be re-used. Remove the front strut brace (if equipped) for additional clearance while working.
4. Release the fuel system pressure by removing the cap on the front end of the driver's side fuel rail and relieve the pressure by pressing in the center of the Schrader valve. A rag over the end of the fuel rail will help contain any fuel that may spill while relieving the pressure.



 **WARNING:** Fuel in the fuel system remains under high pressure even when the engine is not running. Before working on or disconnecting any of the fuel lines or fuel system components, the fuel system pressure must be relieved. Failure to do so can result in personal injury.

 **WARNING:** Do not smoke or carry lighted tobacco or open flame of any type when working on or near any fuel-related components. Highly flammable mixtures are always present and can be ignited, resulting in personal injury.



PREMIUM FUEL REQUIRED

5. Disconnect the (+) positive connection to the battery by removing the red power cable along the driver side inner fender (Do this if battery was not yet disconnected in the trunk).

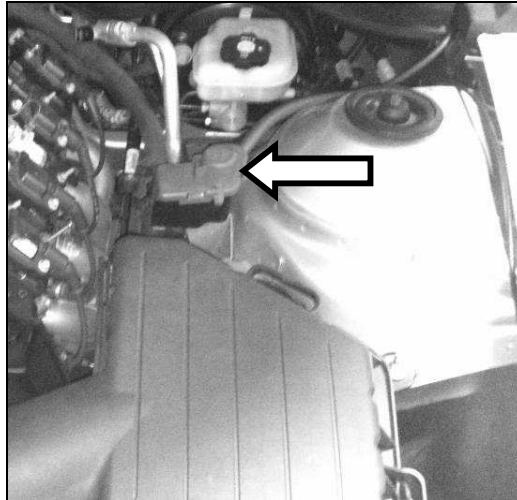

6. If working on a 2010 or 2011 Camaro, complete the following step. If working on a 2012 or newer Camaro, skip to step 6. Drain the cooling system coolant and remove the heater inlet & return hoses that route along the top of the passenger side fuel rail. **IMPORTANT: These need to be replaced with the factory 2012 Camaro Heater lines NOT PROVIDED in this kit. These can be purchased from you local GM dealership (PN 22962570).**

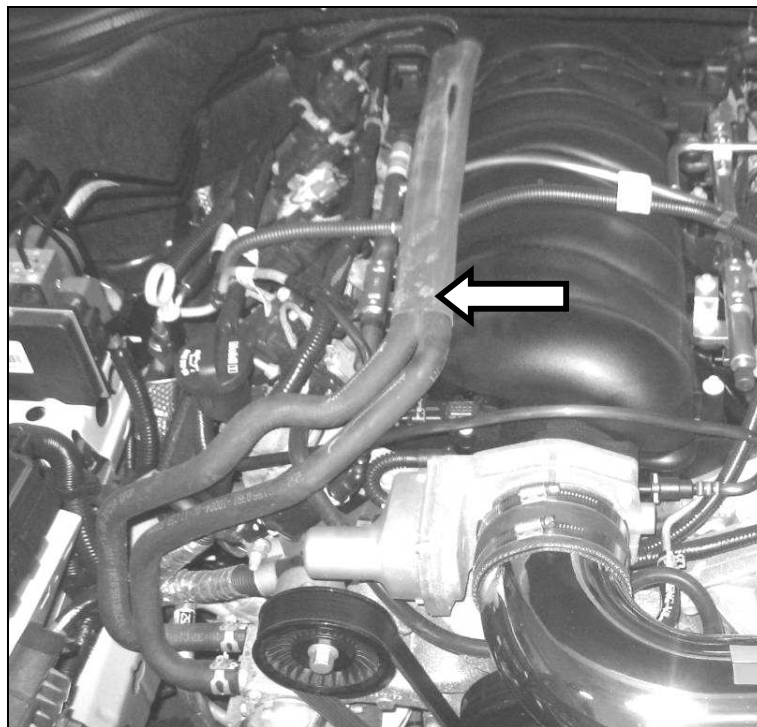

(2010 & 2011 Camaro - Heater Hose Removal)



PREMIUM FUEL REQUIRED

7. Disconnect the PCV Fresh Air Inlet tube from the right-hand (passengers side) near the top of the cam cover and disconnect from the clean air tube. Remove hose from the vehicle.
8. Disconnect the brake booster vacuum hose from the port on the brake booster.
9. Disconnect the clean air tube from the throttle body and the upper airbox lid. Remove the clean air tube from the vehicle.
10. Remove the Mass Air Flow (MAF) sensor electrical connector from the air box, by pulling the white locking tab back and pressing the release tab.

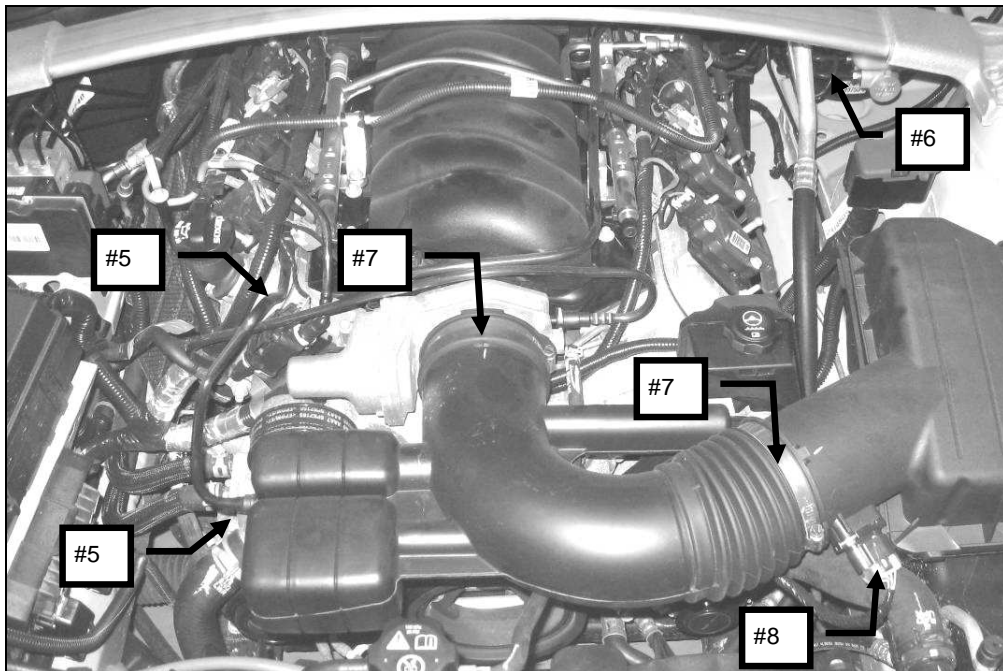

11. Remove the two fasteners securing the airbox assembly to the driver's side fender and remove the entire unit as an assembly from the vehicle. Set these parts aside as they will be re-used.

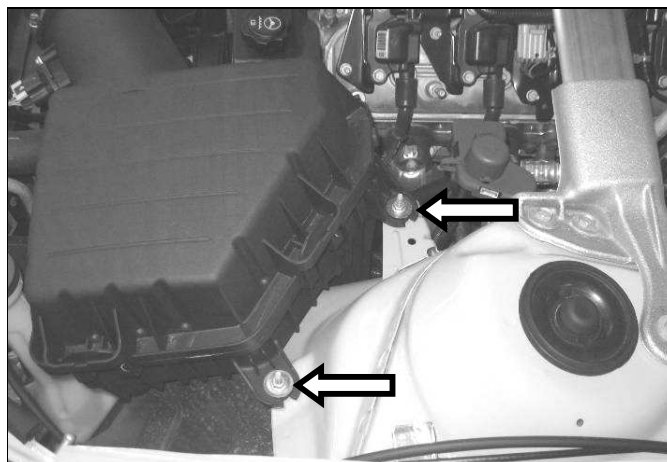



PREMIUM FUEL REQUIRED

12. Place a rag underneath the fuel supply line at the fuel rail joint. Remove the fuel supply line lock, by pulling it up off of the supply line. Remove the fuel inlet supply line from the fuel rail using an SAE J37088-A fuel line tool. Insert the tool into the female connector and push inward to release the locking tabs. With the tabs released, remove the supply line from the fuel rail.

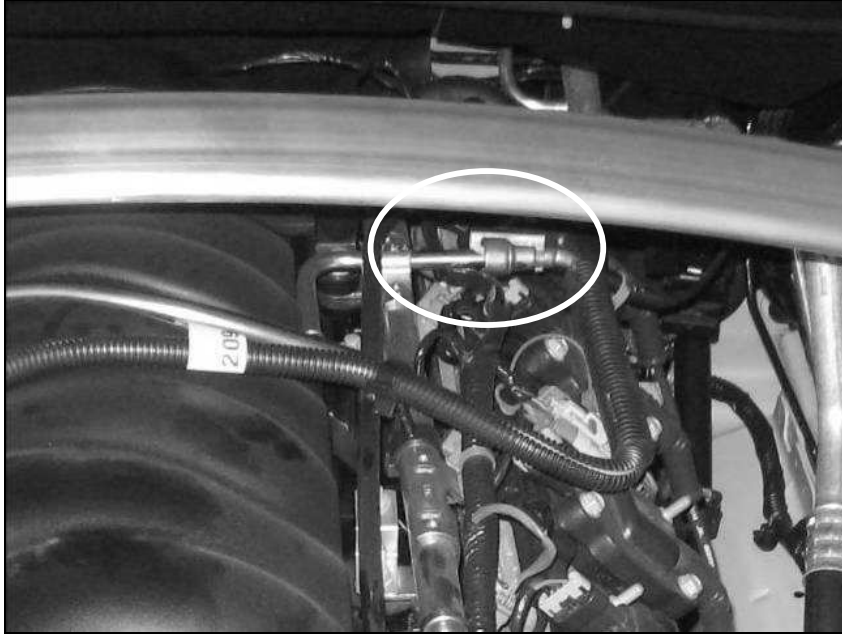

13. Remove the fuel supply line from the vehicle by using the same SAE J37088-A tool and remove the jumper line from the body supply line. This line will not be re-used.

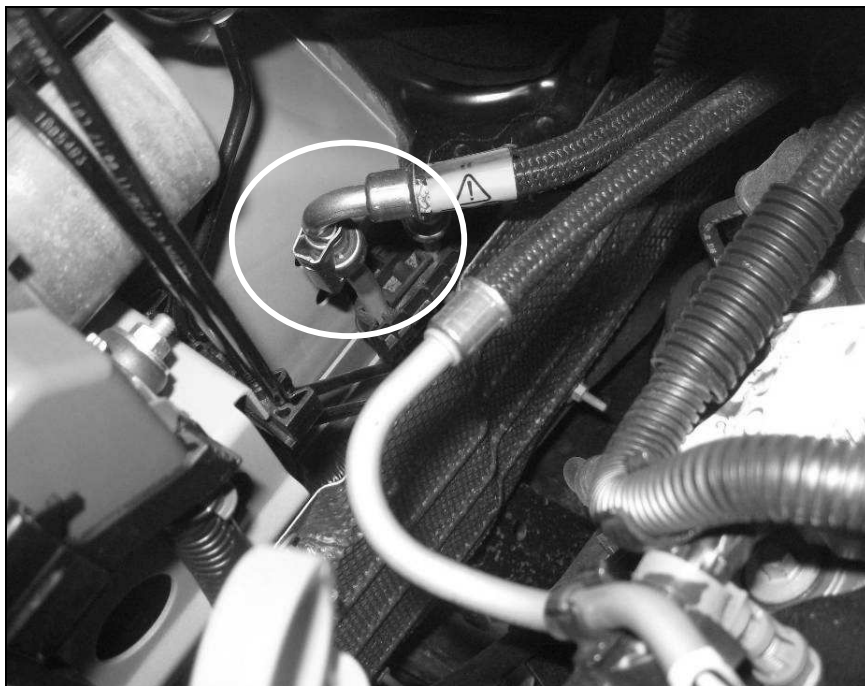



PREMIUM FUEL REQUIRED

14. Disconnect the electrical connector from the manifold absolute pressure (MAP) sensor, located behind the throttle body on the passenger side.

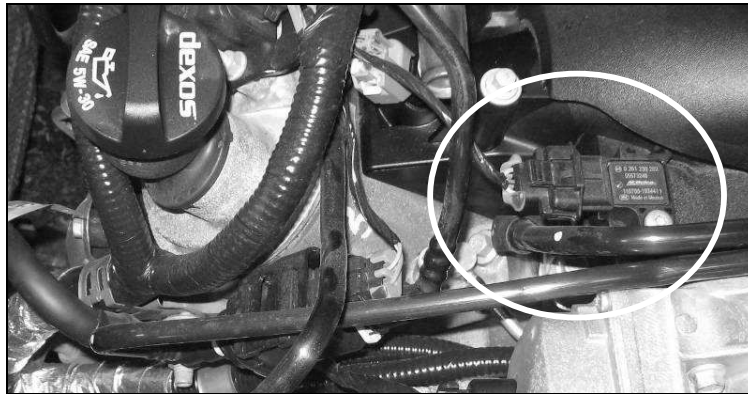

15. Disconnect the EVAP Purge line from the intake manifold behind the throttle body and from the EVAP Solenoid on the front of the passenger side cam cover. Set this aside as it will need to be modified for re-use.
16. Disconnect the PCV line from either the rear driver side cam cover or the port located on the passenger side valley plate cover below the MAP sensor. Disconnect the line from the port on the intake manifold at the opposite end. Set this aside as it will not be re-used.
17. Disconnect the EVAP body line from the EVAP Solenoid and remove it from the retaining clips holding it in place. Carefully position this out of the way as it will be re-connected later.

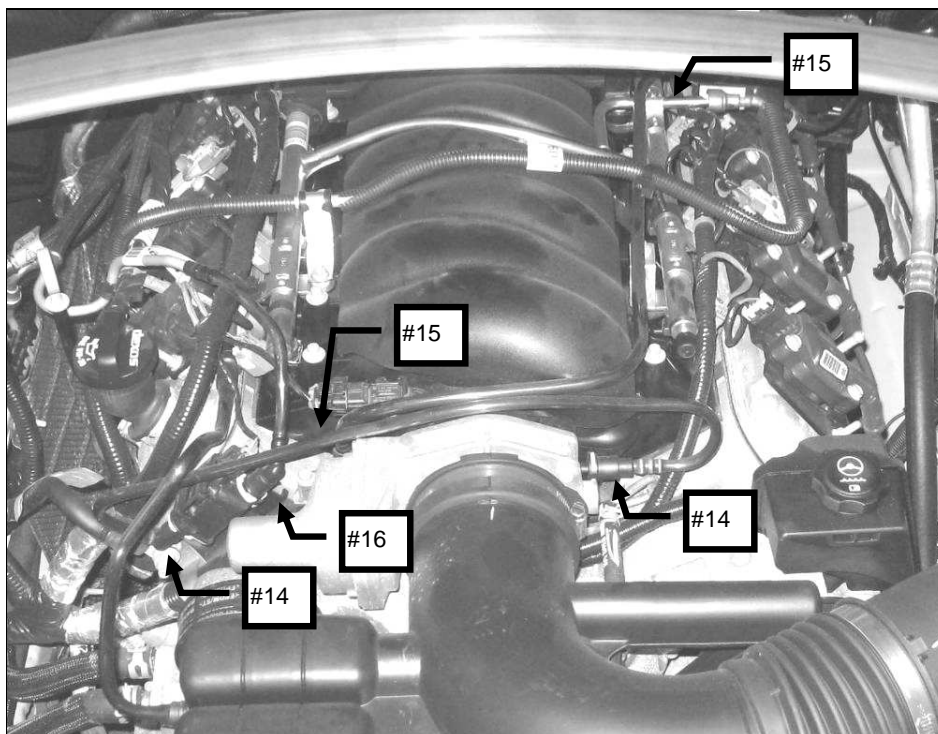



PREMIUM FUEL REQUIRED

18. Disconnect the eight (8) fuel injector electrical connectors.
19. Remove the ten (10) intake manifold mounting bolts and remove the intake manifold and fuel rail assembly as a complete unit from the vehicle. This hardware will not be reused.
NOTE: If you have not yet checked the DOD plate in your vehicle (refer to page 2) do this now.
NOTE: To access one intake bolt, remove engine beauty cover mounting bracket.
20. Clean the intake mounting surfaces and apply tape over the open intake ports to prevent engine contamination.
21. Rotate the tensioner assembly clockwise and remove the accessory drive belt from the engine. It will not be re-used.
22. Remove the tensioner assembly and fasteners. Set the bolts aside as they will be re-used.
23. Remove the bolt circled in the picture below.

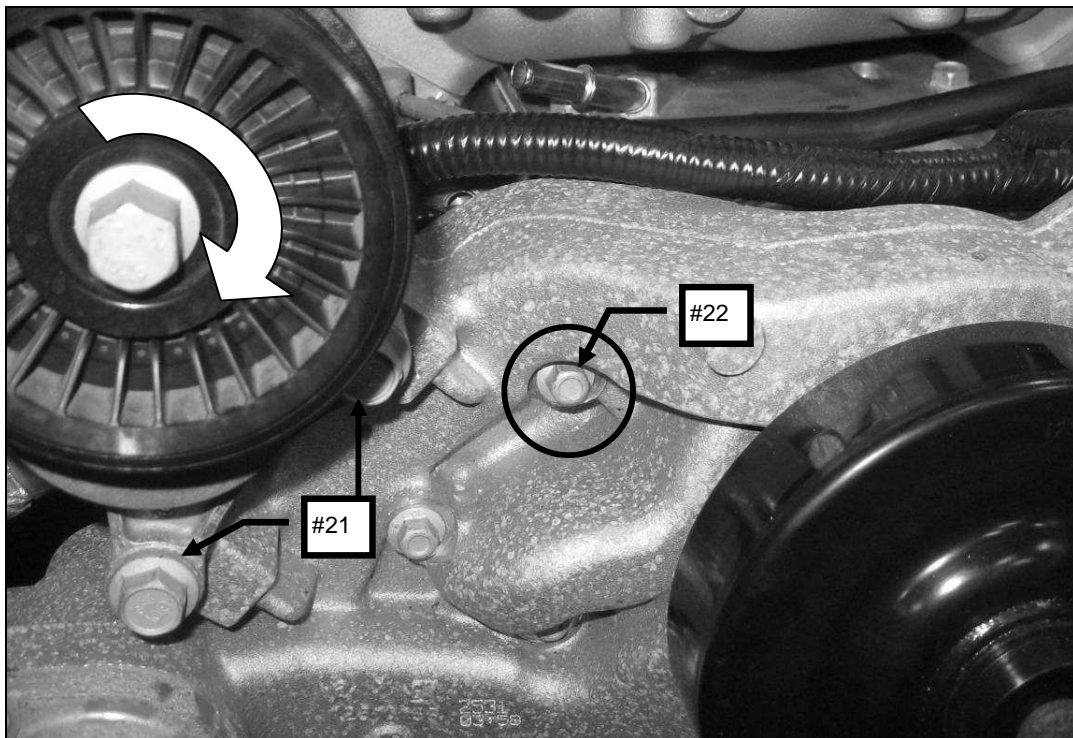



PREMIUM FUEL REQUIRED

24. Remove both the left hand and right side cooling module mounting brackets. Set these aside as one will be re-used and the grommet from the second will be re-allocated to a new bracket.

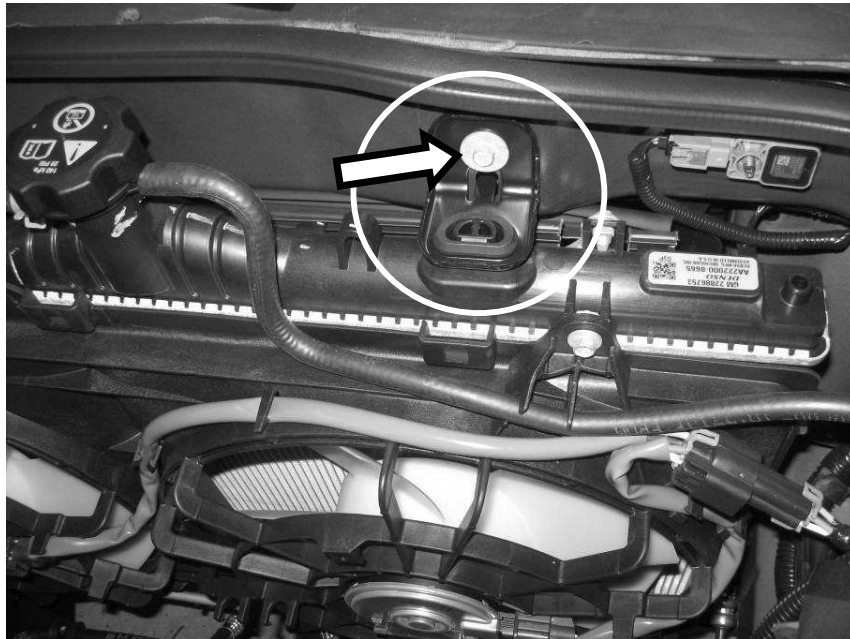

25. Push the entire cooling module towards the engine and remove the top close out panel that rests along the top edge of the A/C Condenser. Set this aside as it will be re-used.

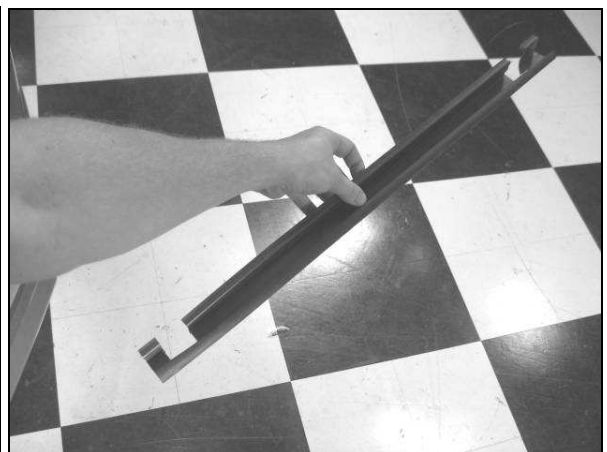
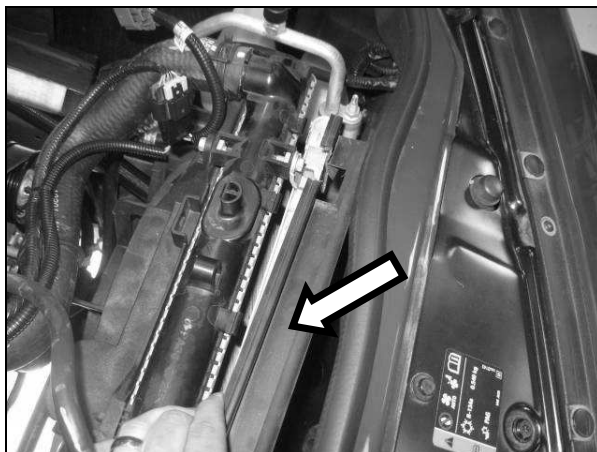



PREMIUM FUEL REQUIRED

SECTION B – MODIFICATIONS

The following section will guide you through the required modifications of existing components and build up of the assemblies used to complete the installation. All of this work can be performed away from the vehicle.

Throttle Body Removal

1. Remove the four (4) bolts that retain the factory electronic throttle body from the intake manifold assembly that was previously removed from the engine. Retain the gasket as it will be re-used with the new supercharger.

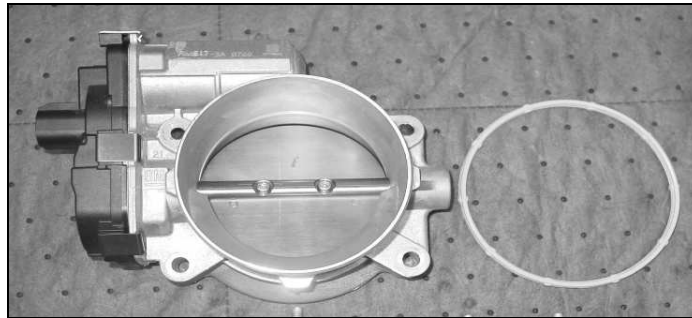

EVAP Solenoid Relocation

1. Remove the bolt that secures the EVAP solenoid bracket to the front of the passenger side cylinder head. Remove the Stud that retains the wiring p-clip and ground wire to the lower bolt hole on the front face of the passenger cylinder head.
2. Undo the electrical connection to the EVAP Solenoid and remove the solenoid from the bracket by pressing down on the center of the lock mechanism.
3. Bend the anti-rotation tab on the bracket flat as shown below.

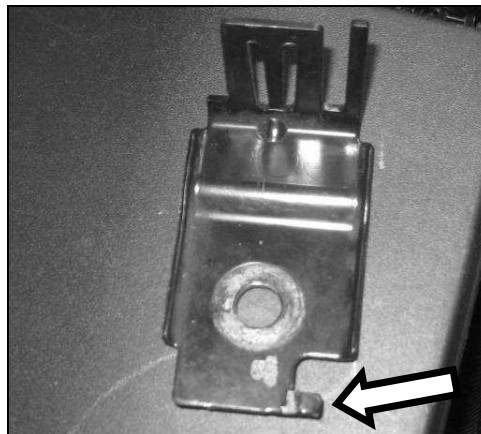



PREMIUM FUEL REQUIRED

4. Re-install the bracket and position it against the lower mounting hole on the cylinder head. Put the ground wire on top of this and install the fastener. (Remove the anti-rotation tab off of the ground eyelet). Torque to 25 Nm.

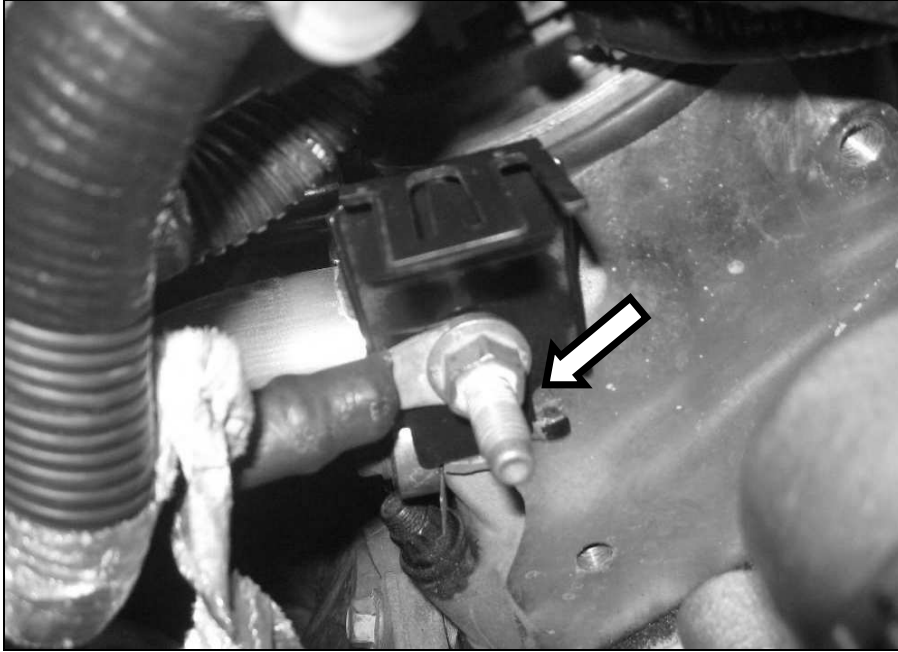

5. Re-install the EVAP solenoid onto the top of the bracket in the new mounting position.
6. Flip the wiring harness p-clip on the harness and slide towards the top mounting hole. Insert the bolt that retained the EVAP solenoid. Torque to 25 Nm. Note: Adjustments may be needed for proper wiring slack once the new Throttle Body position is in place.

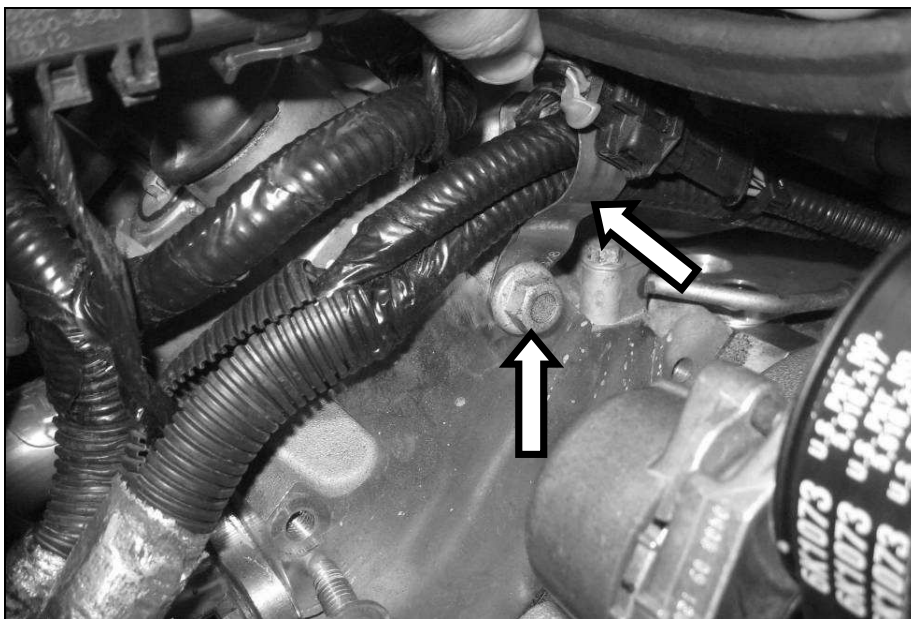



PREMIUM FUEL REQUIRED

7. Reinstall the EVAP Solenoid onto the bracket and connect the electrical connector and EVAP quick connect fitting from the body line. The new position and wiring routing should now look like this.

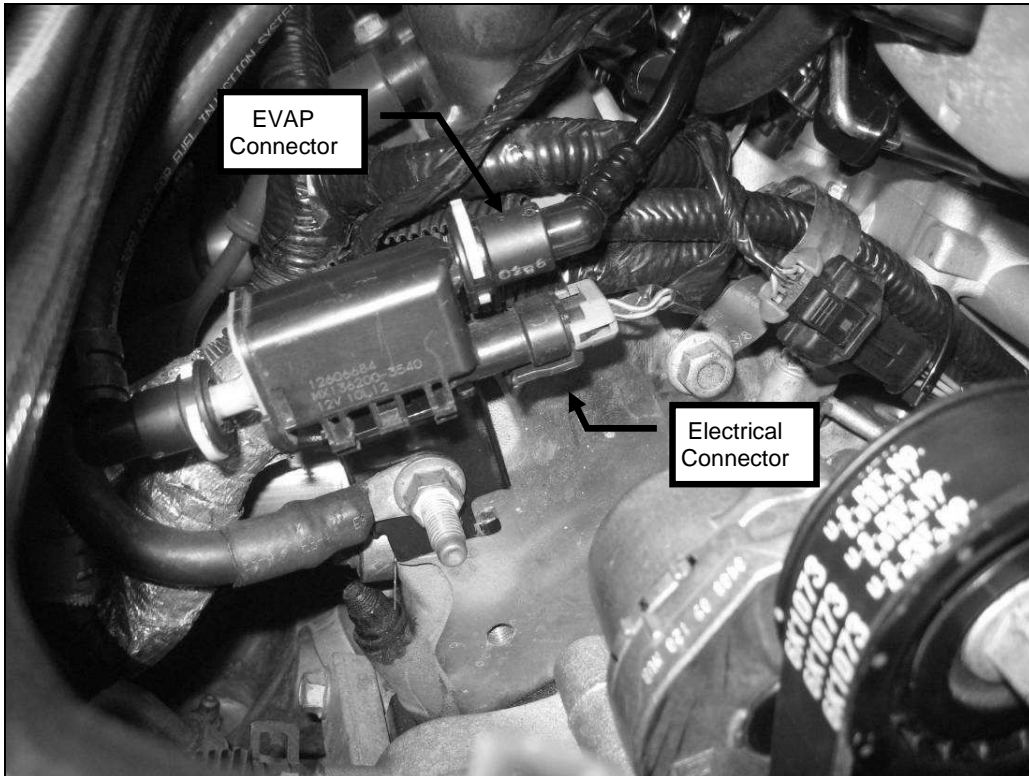



PREMIUM FUEL REQUIRED

SECTION C – SUBASSEMBLY

Intercooler Low Temperature Radiator (LTR)

1. Position the Low Temp Radiator – (LTR) (HH-8K229) face down on a suitable working surface.
2. Take the two (2) long 12.7mm thick pieces of insulation tape (HH-8K232) found in Hardware Kit F (HH-HWKF), remove the adhesive backing and position them along the top and bottom surfaces of the LTR along the edge of the header tanks as shown.

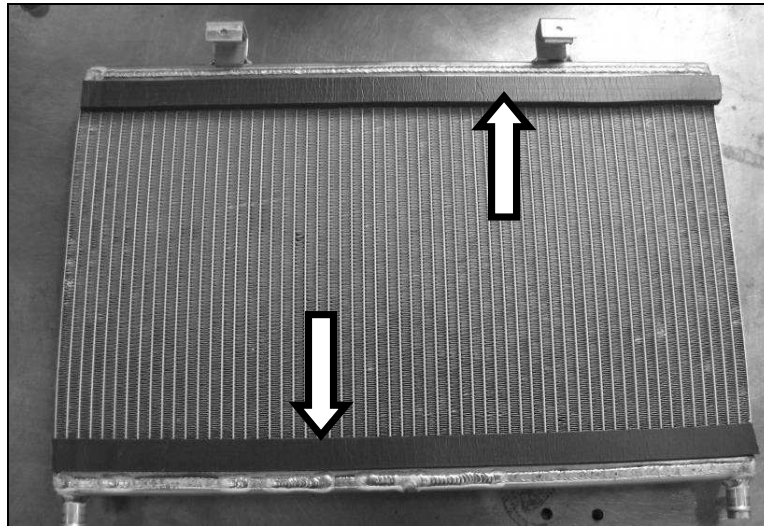

3. Take the two (2) short 4.7mm thick pieces of insulation tape (HH-8K231) found in Hardware Kit F (HH-HWKF), remove the adhesive backing and place these along the inside surface of the two mounting brackets.

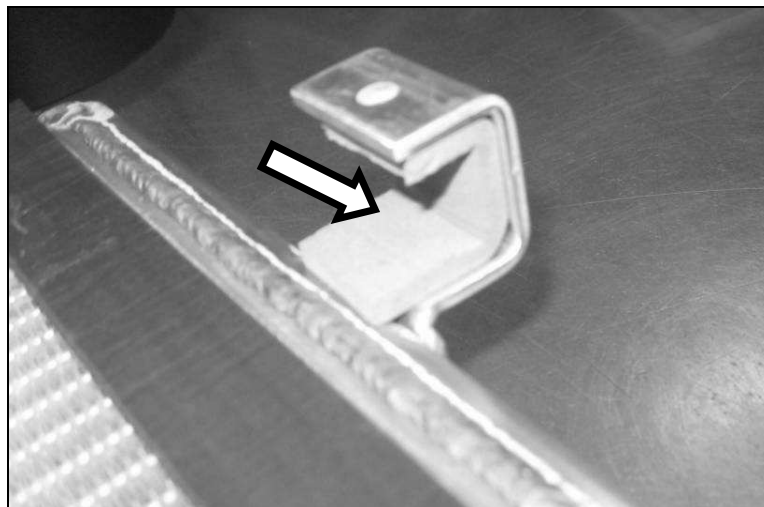



PREMIUM FUEL REQUIRED

4. Install the 1/8" pipe plug (W706310) into the top of the header tank. This can be found in Hardware Kit F (HH-HWKF). Note – Do not fully tighten at this time. When filling the intercooler system with coolant, this may need to be removed to help remove trapped air from the system.

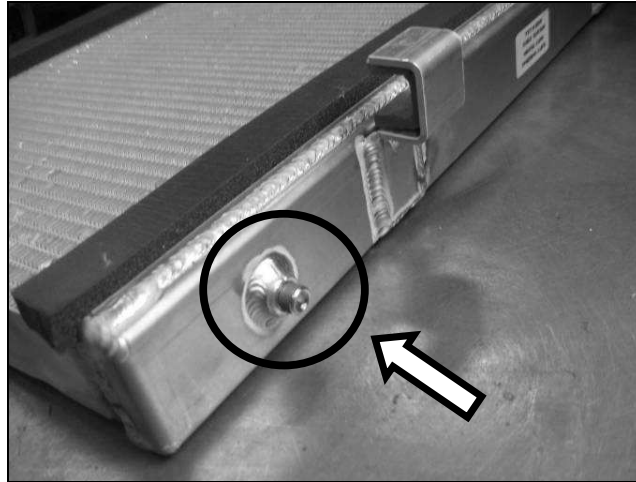

EVAP Hose Assembly

1. Remove the 90° quick connect fitting from the EVAP line that was removed from the vehicle.
2. Insert the quick connect fitting into one end of the new EVAP Hose (HH-9G297) found in Hardware Kit D (HH-HWKD).

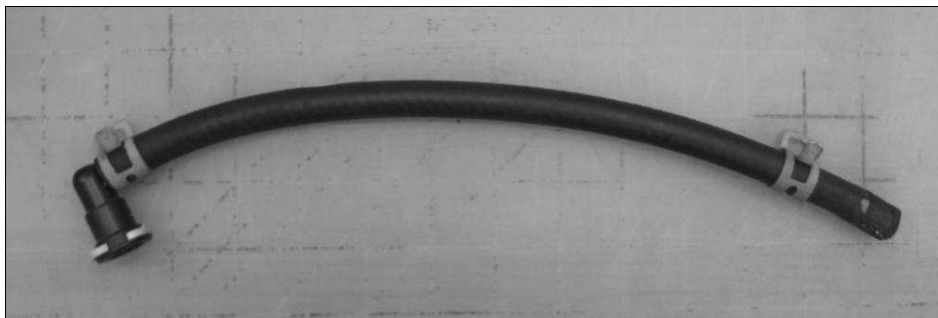



PREMIUM FUEL REQUIRED

Intake Manifold Assembly

1. Remove the Fuel Charging Assembly (HH-9H487) from the packaging. Carefully place it upside down onto a clean and sturdy work area.
2. Insert the eight (8) individual intake manifold gaskets (19256623) around each of the intake manifold runner ports as shown. These can be found in Hardware Kit A (HH-HWKA).

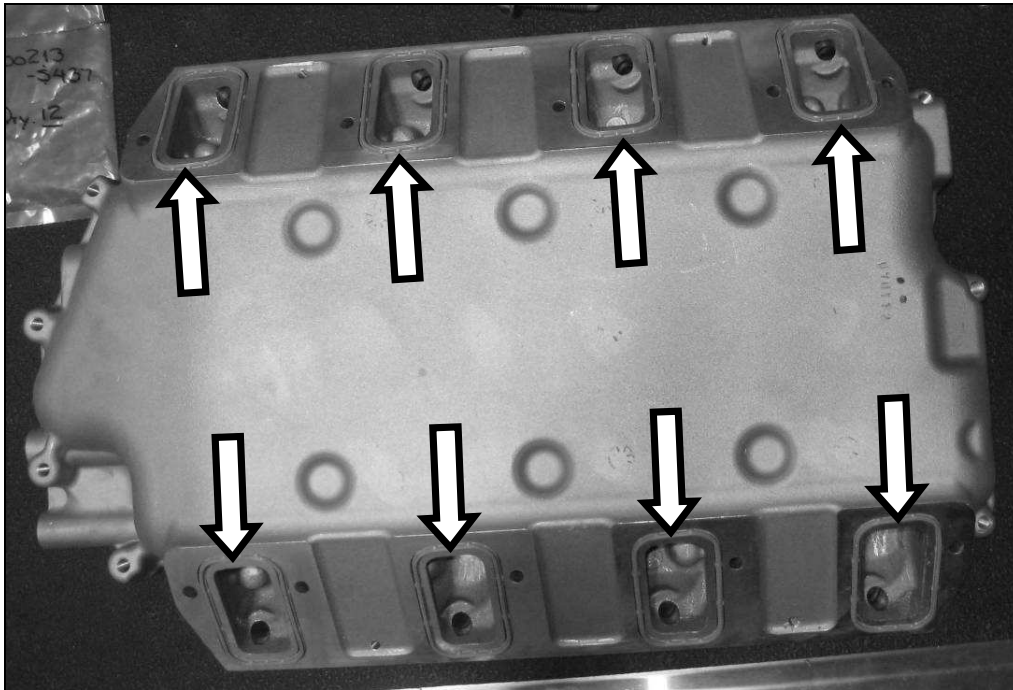

3. Apply some o-ring lubricant onto the new 2 Bar MAP Sensor (90423637) and install into the front of the intake manifold. Install the M6x16 fastener (W500213). These can be found in Hardware Kit A (HH-HWKA). Torque to 10 Nm.

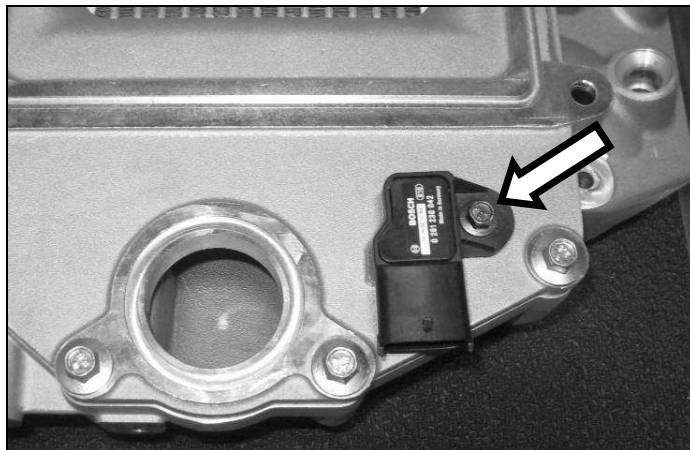



PREMIUM FUEL REQUIRED

4. Lube the fuel injector o-rings with assembly lube. Install the eight (8) Fuel Injectors (0280158187) into the fuel charging assembly with the electrical connectors facing outboard. These can be found in Hardware Kit A (HH-HWKA). Install the fuel injector clips from the factory fuel rail.

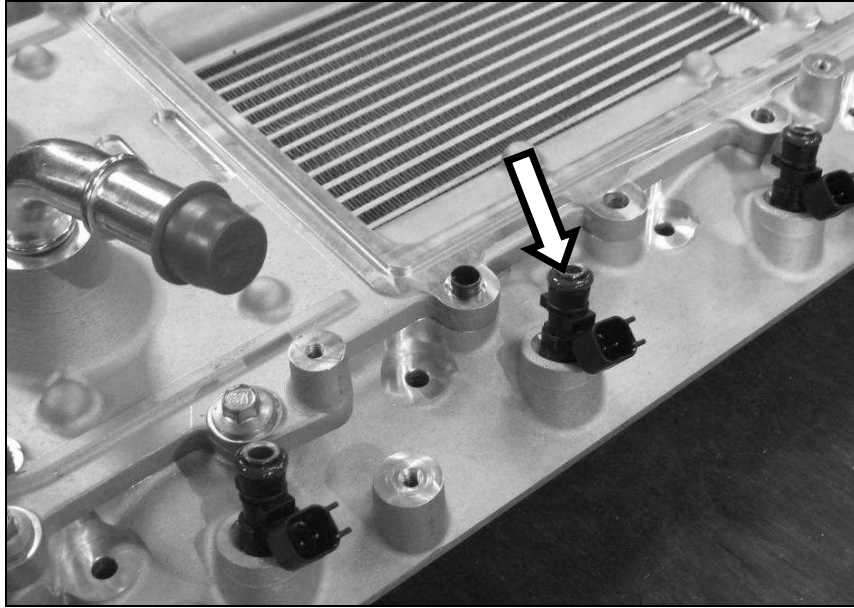

5. Gently place the fuel rail (HH-9F792) over the top of each injector. Ensure that the rear cross over is routed underneath and behind the coolant tubes on the intake. Seat the fuel rail onto each injector and then install the four (4) fuel rail mounting bolts (R18020009) found in Hardware Kit A (HH-HWKA). Torque to 10 Nm.

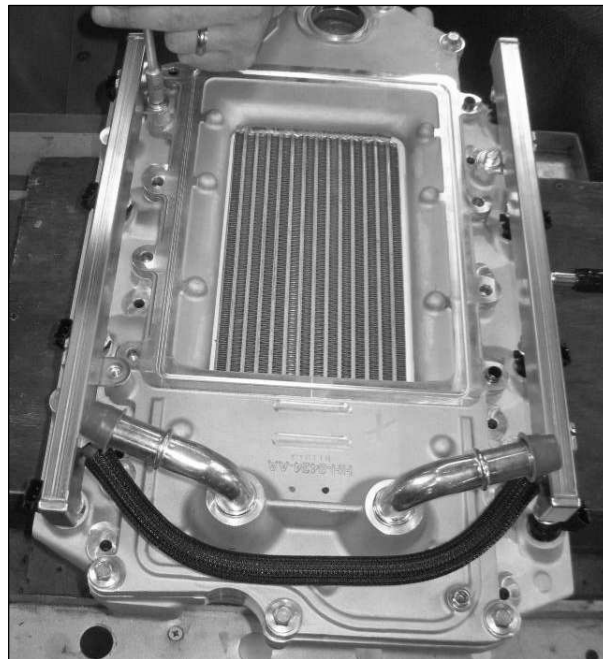



PREMIUM FUEL REQUIRED

6. Install the supercharger sealing gasket (R07060166) as well as the supercharger bypass gasket (R07060183) into the machined grooves on the upper intake. These can be found in Hardware Kit A (HH-HWKA).

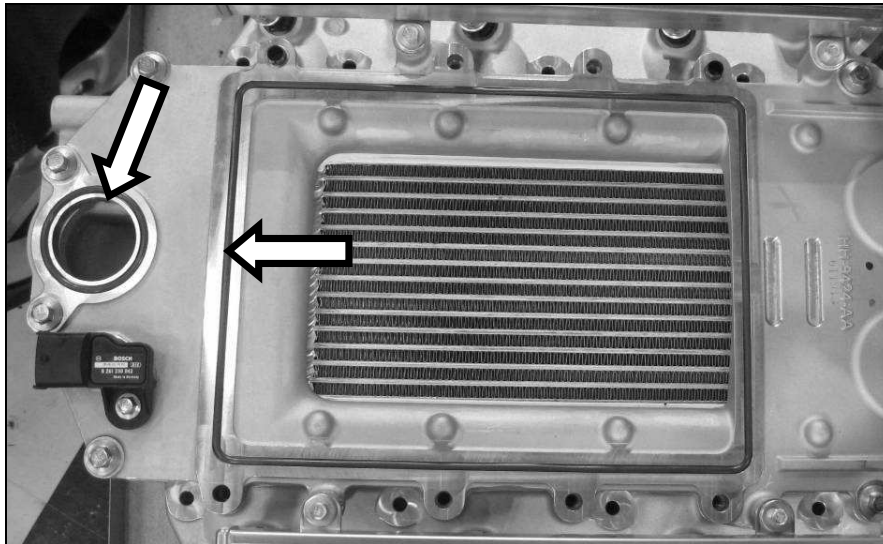

Note – There is a 1/8" NPT threaded port located in the rear passenger side corner of the upper intake manifold. This port comes with a plug installed from SLP. This port location was provided as a manifold vacuum/pressure source for a boost gauge or for vehicles equipped with the active exhaust option. Fitting not provided.

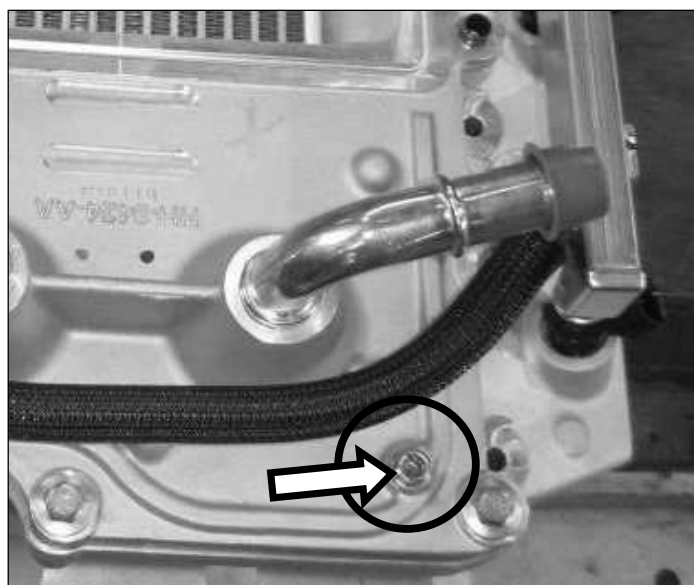



PREMIUM FUEL REQUIRED

Degas Bottle Mounting Bracket

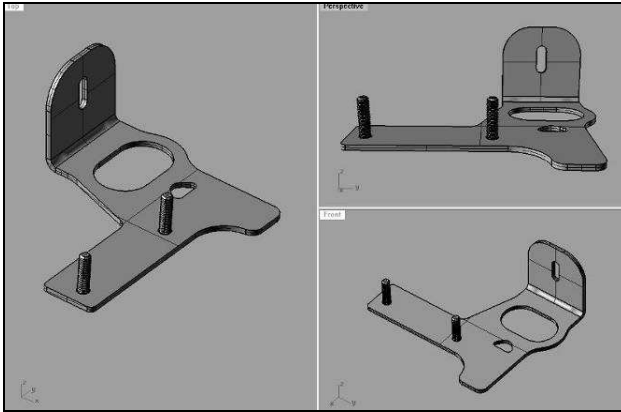

2010 – 2011 Degas Bottle Bracket
(HH2010-6B634)

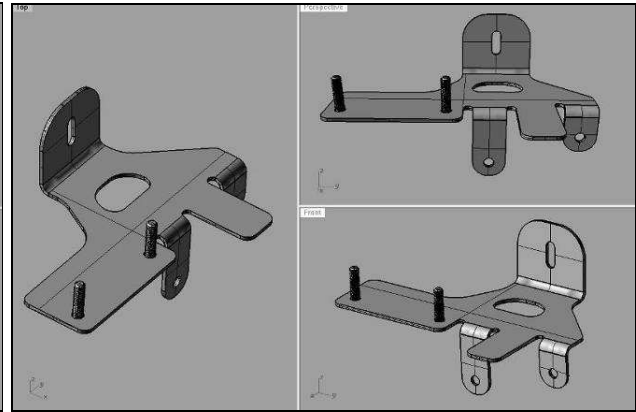

2012-2014 Degas Bottle Bracket
(HH-6B634)

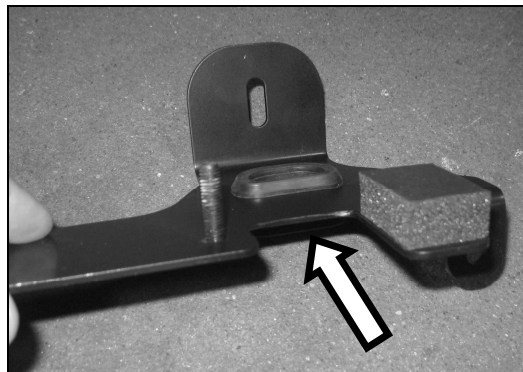

2014 VEHICLES ONLY – CUT OFF MOUNTING LEG AS SHOWN

1. Locate one of the factory cooling module mounting brackets that was removed during dis-assembly. Remove the rubber grommet from the bracket.





PREMIUM FUEL REQUIRED

2. Choose the correct Intercooler Degas Bottle Mounting Bracket (HH-6B634 / HH2010-6B634) for your specific model year vehicle. Swap the rubber grommet from the original bracket to the new bracket (2012 bracket shown, 2010 bracket similar).



3. Remove the adhesive backing from the 35mm long 12.7mm thick foam tape (HH-8K233) found in Hardware Kit F (HH-HWK F) and install this onto the surface of the degas mounting bracket where the reservoir will sit. (2012 bracket shown, 2010 bracket similar).

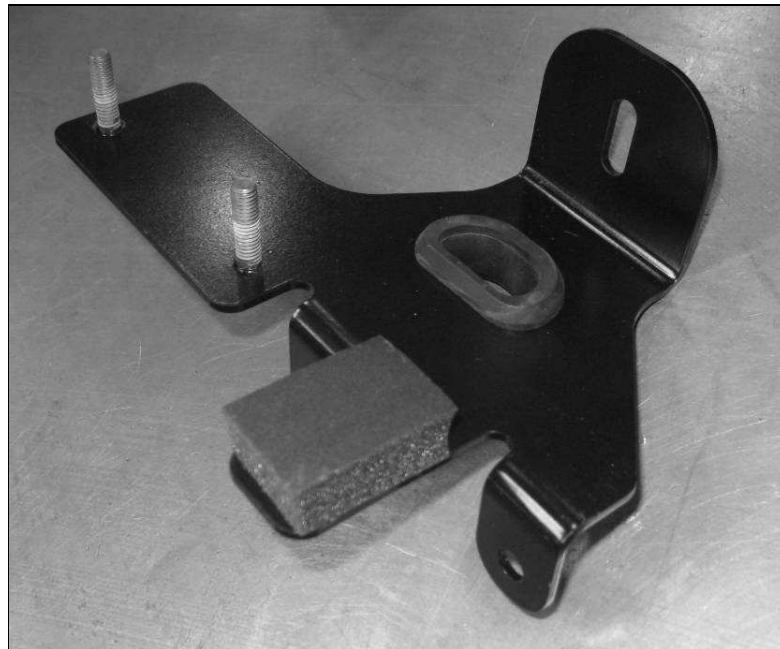



PREMIUM FUEL REQUIRED

I/C Pump Wiring Harness

1. Remove the Intercooler Pump Wiring Harness (HH-8W501) from Hardware Kit C (HH-HWKC).

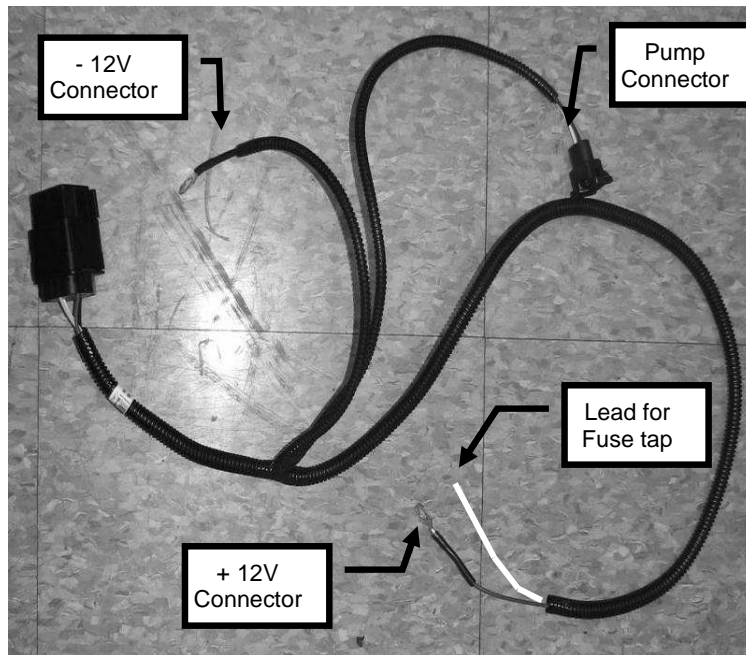

2. Connect and secure the Fuse Tap (R18060010) found in Hardware Kit C (HH-HWKC) to the lead for the fuse tap on the wire harness indicated above.
3. Install the 10 amp fuse (08N2483) found in Hardware Kit C (HH-HWKC) into the top location of the fuse tap.





PREMIUM FUEL REQUIRED

SECTION D – INSTALLATION

The following section will guide you through the final installation of the kit into the vehicle. If you need to stop during any part of the installation, make sure you cover any open ports in the cylinder heads or intake manifold to prevent foreign material from contaminating your engine.

Intake Manifold and Supercharger Installation

1. Connect the new PCV Fresh Air Hose (HH-6758) to the port on the front corner of the passenger side cam cover. Lay the hose off to the side as it will be connected in a later step.

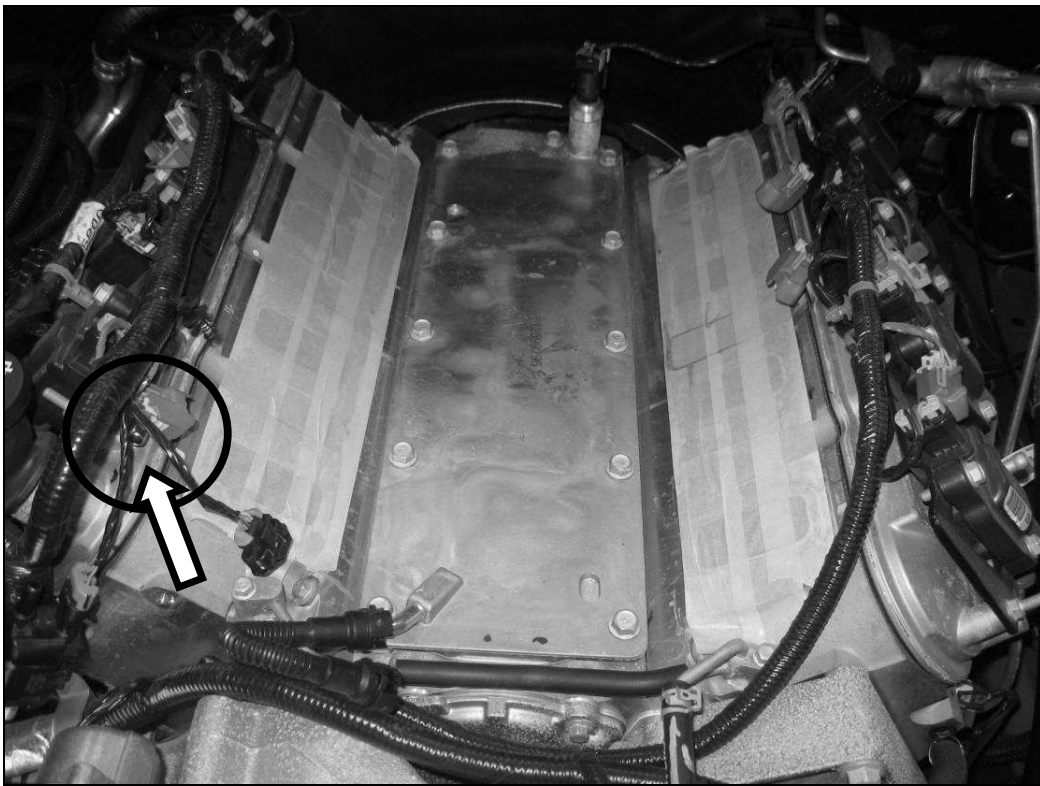

2. Remove the tape or protective covering from the cylinder heads and clean the cylinder head to intake manifold mating surfaces.



PREMIUM FUEL REQUIRED

- Carefully place the fuel charging assembly onto the cylinder head mounting surface. NOTE: Do not use the two tubes at the rear of the intake as handles. Install the ten (10) M6x74.5 intake mounting bolts (N807072). These can be found in Hardware Kit A (HH-HWKA). Install these fasteners in the positions shown and tighten the sequence in two stages. Stage 1; torque bolts to 10 Nm. Stage 2; tighten bolts an additional 45 degrees.

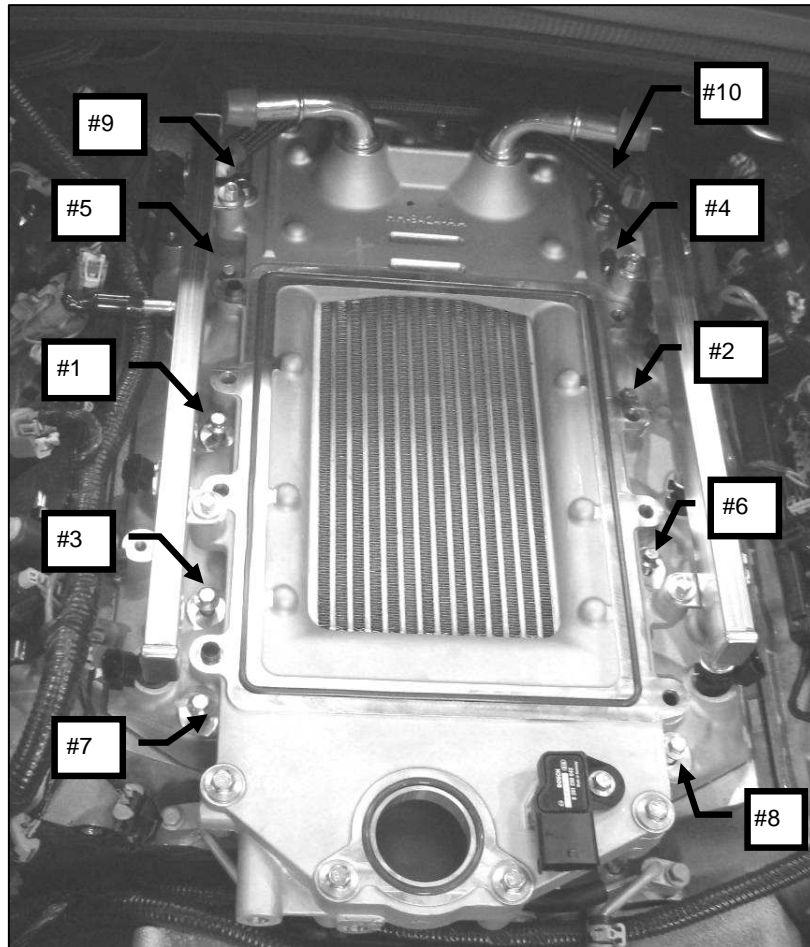

- Connect the eight fuel injector electrical connectors.
- Remove the supercharger assembly (HH-6F066) from the protective packaging and place on a workbench or solid flat surface. Remove the protective shipping covers.



PREMIUM FUEL REQUIRED

6. Install the 98mm supercharger pulley (HH-6K98) onto the hub of the supercharger using the six (6) M6x16 fasteners (W500013) found in Hardware Kit B (HH-HWKB). **NOTE: For proper orientation, the part number of the pulley is supposed to face towards the supercharger, you should not see it when the pulley is installed.** Apply a small amount of blue thread locking compound to the bolts, and torque to 10 Nm. (TIP: Torque these bolts once the FEAD Belt has been installed to keep the Supercharger from rotating).



7. Install the SLP Badge (010036203) and the TVS2300 Badge (010036202) to the supercharger using the four (4) M4x16 fasteners (940706400) found in Hardware Kit A (HH-HWKA). Apply a small amount of blue thread locking compound to the bolts and torque to 3 Nm.
8. Connect the supercharger bypass reference vacuum line (R18140001) found in Hardware Kit D (HH-HWKD) from the port on the bypass actuator to the rear port on the passenger side of the supercharger.

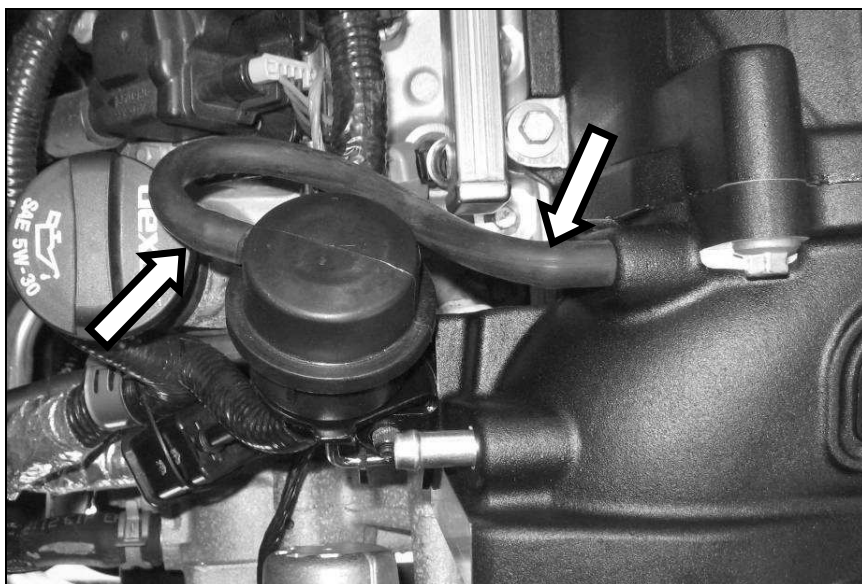



PREMIUM FUEL REQUIRED

9. With the help of an assistant, carefully place the supercharger on top of the intake manifold.. Ensure that the supercharger is fully seated on the intake mounting dowels.
10. Install the ten (10) M8 x 53 fasteners (N808130) into the supercharger mounting holes. These can be found in Hardware Kit A (HH-HWKA). Torque fasteners in three steps; 10Nm, 20Nm and 30Nm in the sequence shown.

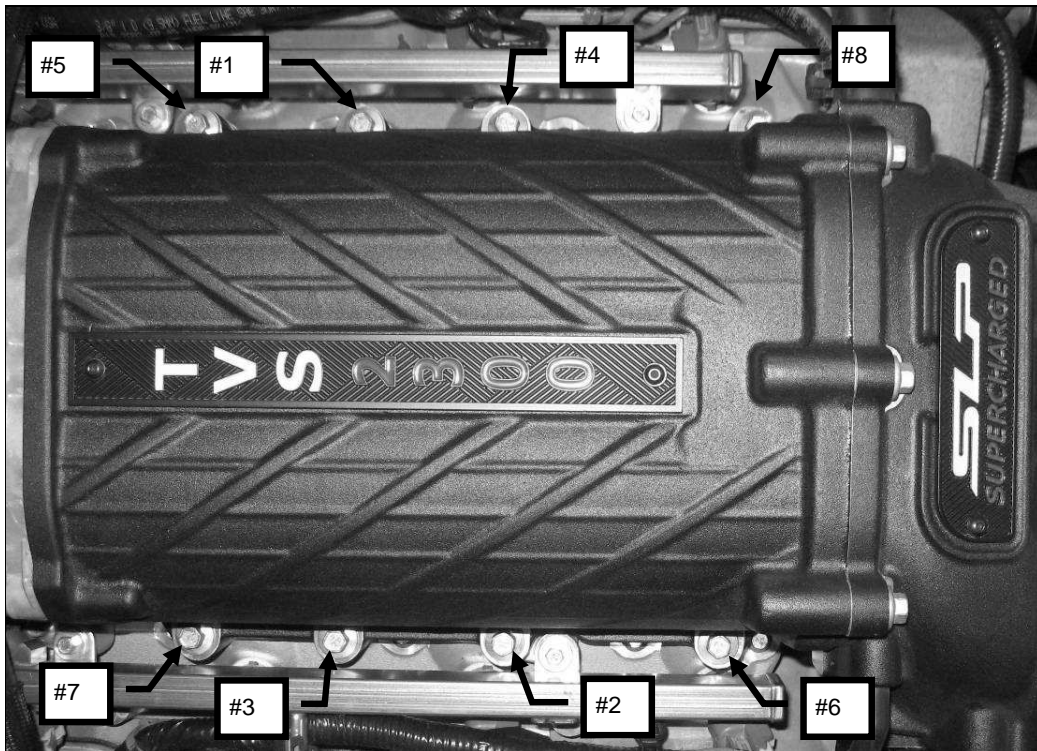

11. Install the factory throttle body gasket into the machined grooved of the supercharger and mount the throttle body using the four (4) M6 x 40 fasteners (R18020004). These parts can be found in Hardware Kit A (HH-HWKA). Torque the fasteners to 10 Nm.

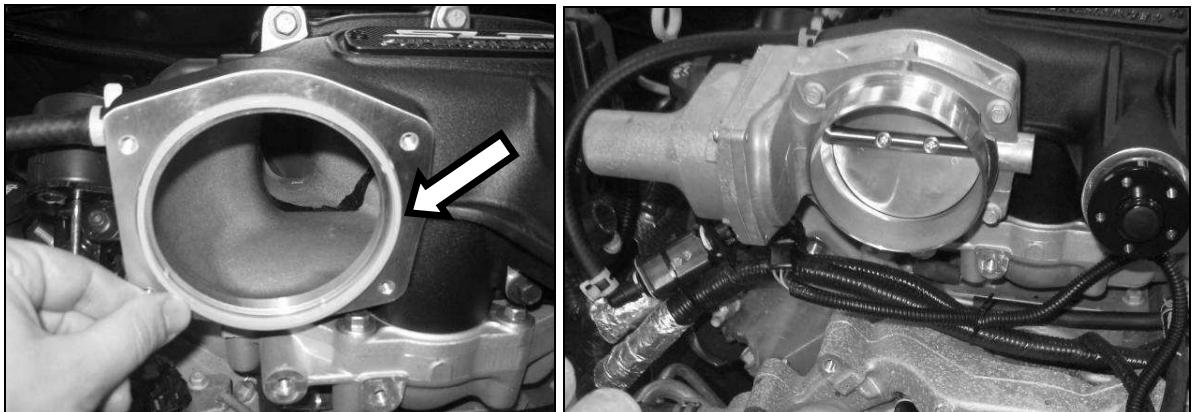



PREMIUM FUEL REQUIRED

12. Re-connect the electrical connector for the Throttle Body. Re-adjust the wiring harness P-Clip in the bundle if more slack is need to make the connection.
13. Connect the new PCV Hose (HH-6K817) to the rear port on the driver side cam cover. Place a $\frac{1}{2}$ " clamp (2UTG7) onto each end of the new Brake Booster Hose (HH-2B432) and connect to the port on the brake booster. These can be found in Hardware Kit D (HH-HWKD).

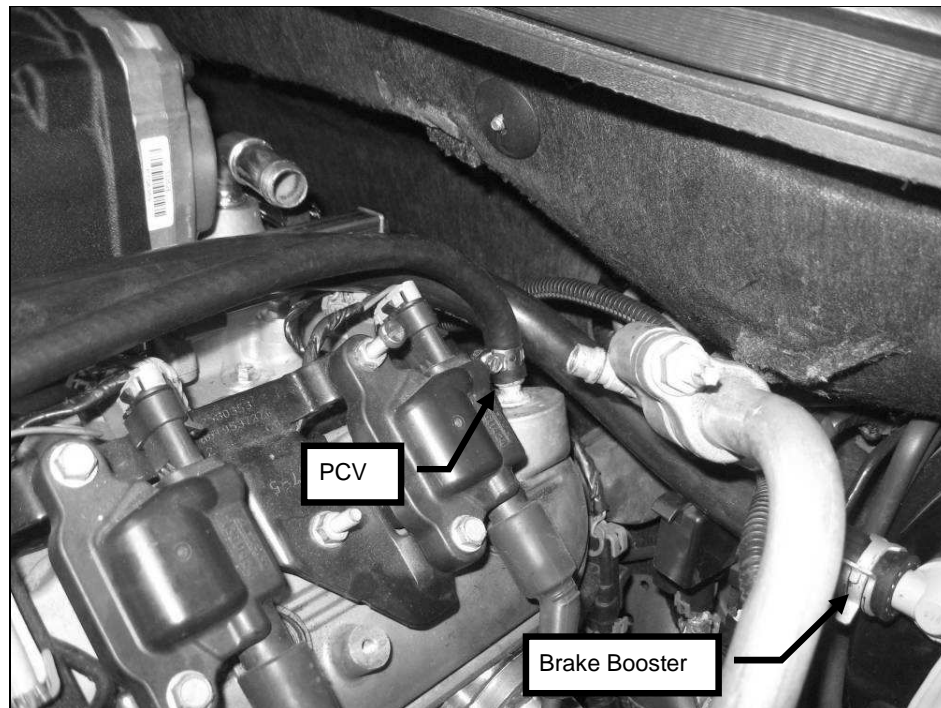

NOTE: Some vehicles will have a cap (A) on this port on the cam cover. Remove this cap and place it on the open port (B) of the tube coming from the engine valley plate, underneath the front of the intake.

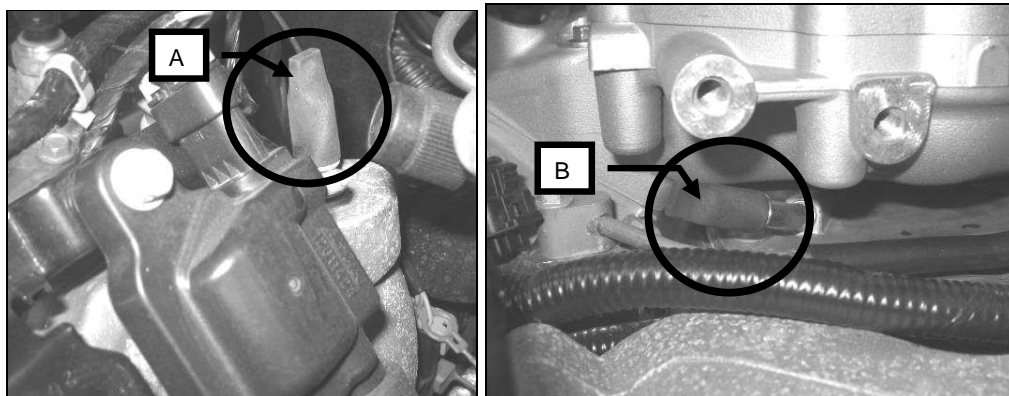



PREMIUM FUEL REQUIRED

14. Connect the opposite end of the PCV Hose to the lower port of the supercharger and the Brake Booster Hose to the top port of the supercharger on the driver side.

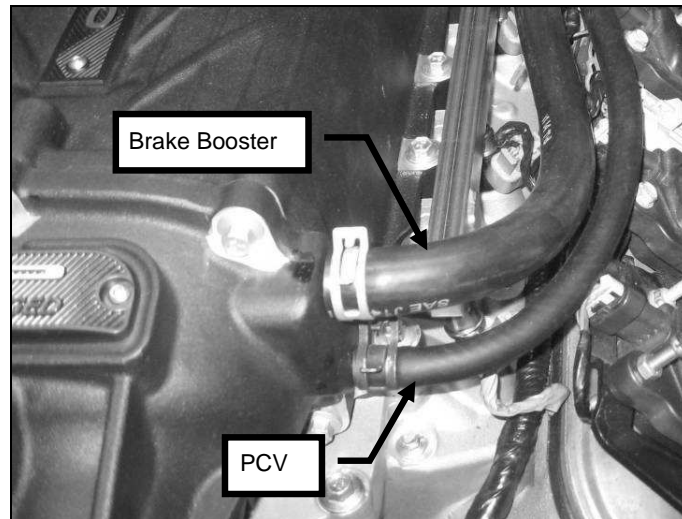

15. Connect the new EVAP hose (HH-9G297) to the quick connect fitting on the EVAP solenoid and route to the forward port on the passenger side of the supercharger.

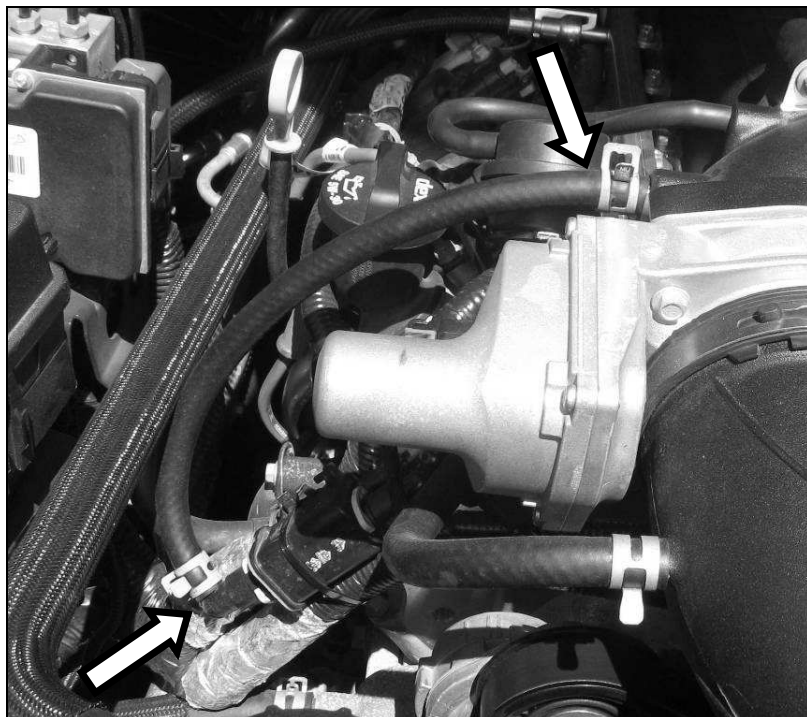



PREMIUM FUEL REQUIRED

16. Connect the fuel supply line (HH-9E964) to the inlet of the fuel rail and the body side fuel line. Secure the factory locks into position on each end.



FEAD Assembly

1. Install the new Tensioner Assembly (12569301) provided using the factory mounting bolts. Torque to 25 Nm.

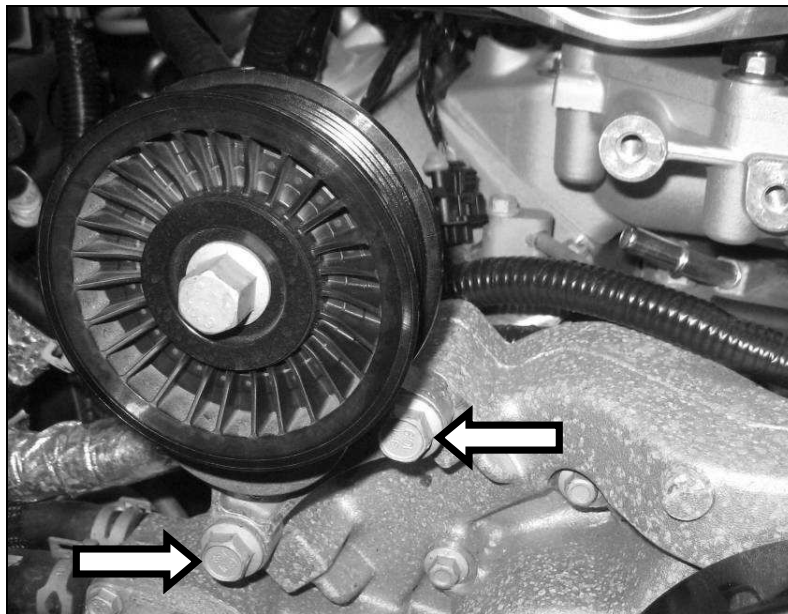



PREMIUM FUEL REQUIRED

2. Install the new Idler Mounting Bracket (HH-8B653) to the front of the intake manifold and water pump housing using three (3) washers (M82MM), two (2) M8 x 95 mm bolts (HHCS8X1.25X95) and one (1) M8 x 130 mm bolts (HHCS8X1.25X130) from Hardware Kit B (HH-HWKB). Torque the bolts to 25 Nm.
3. Install the new Idler Pulley (08567-32) onto the machined posts of the Upper FEAD Bracket. Secure the pulley using one (1) M8 x 1.25 x 28mm idler bolt (R18020060) found in Hardware Kit B (HH-HWKB). Torque bolts to 25 Nm.

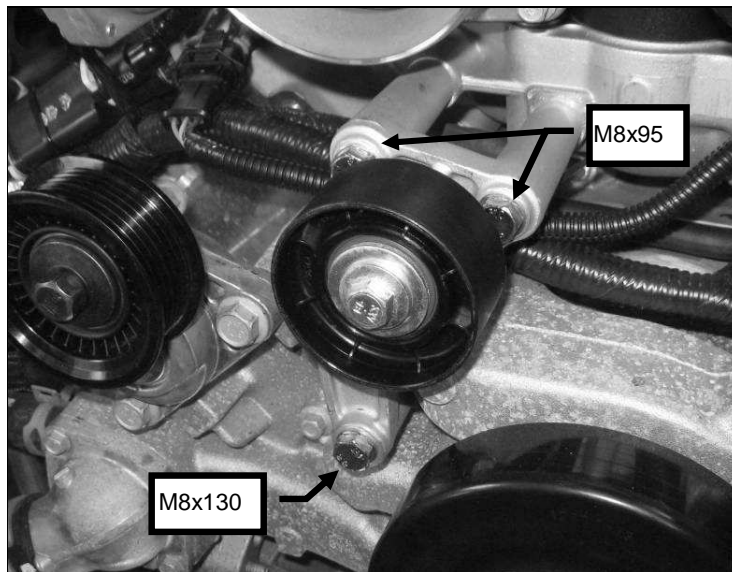

4. Route the new FEAD Belt provided per the schematics shown. Note different belts are included in this kit to fit the different model year vehicles. (Belt PN 904068124 / 904068125)

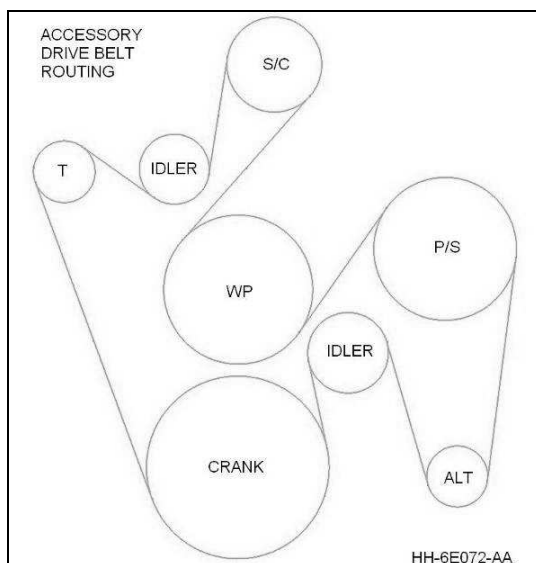

2010 – 2012 Camaro: Belt K061037

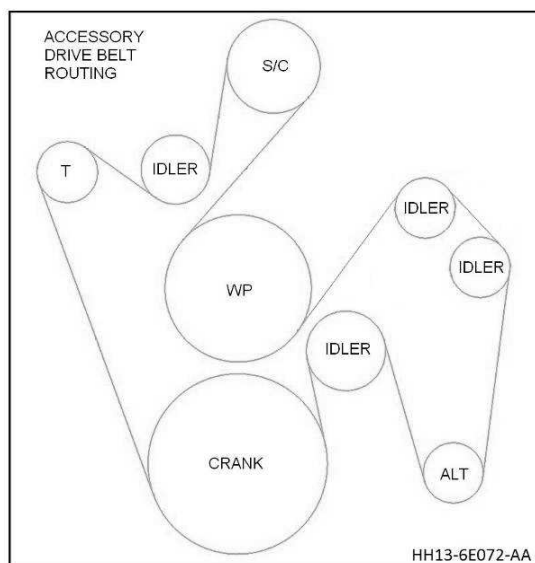

2013 + Camaro: Belt K061000



PREMIUM FUEL REQUIRED

Wiring

1. Route the new TMAP / MAF Harness (HH-12A690) found in Hardware Kit C (HH-HWKC) underneath the new idler bracket and connect the vehicle MAP sensor electrical connector to the mating electrical connector on the new TMAP / MAF Harness.

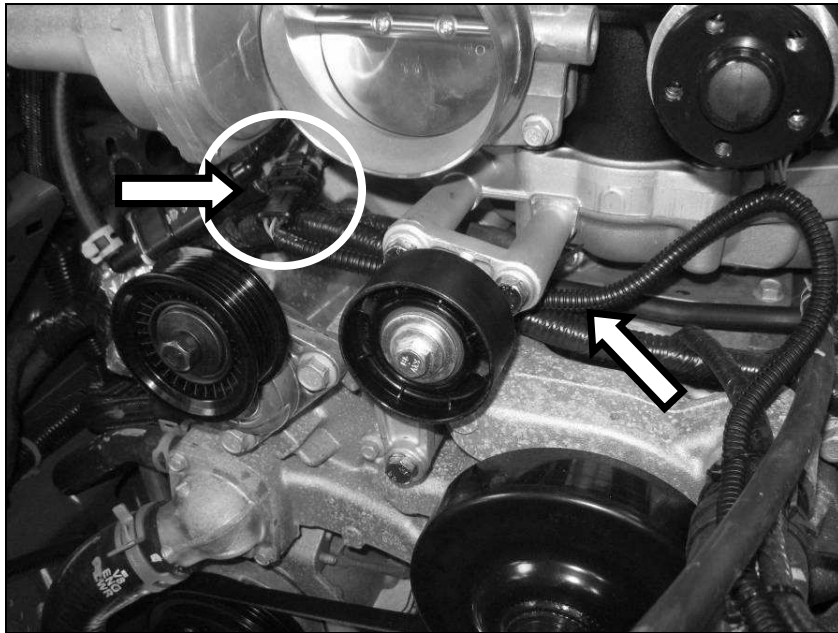

2. Connect the new harness to the TMAP Sensor, located below the snout of the supercharger.

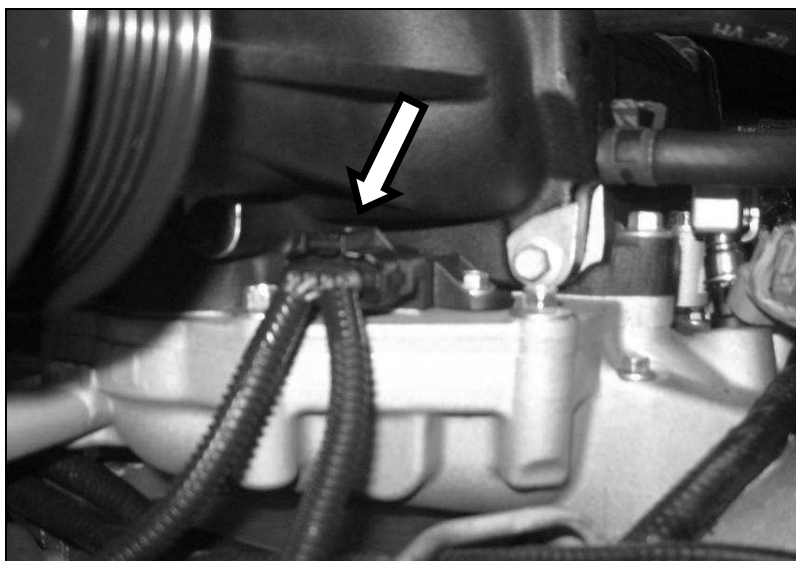



PREMIUM FUEL REQUIRED

3. Route the remaining length of the new harness along the top of the upper radiator hose and secure using zip ties. Connect the vehicle wiring harness MAF sensor connector to the new harness.

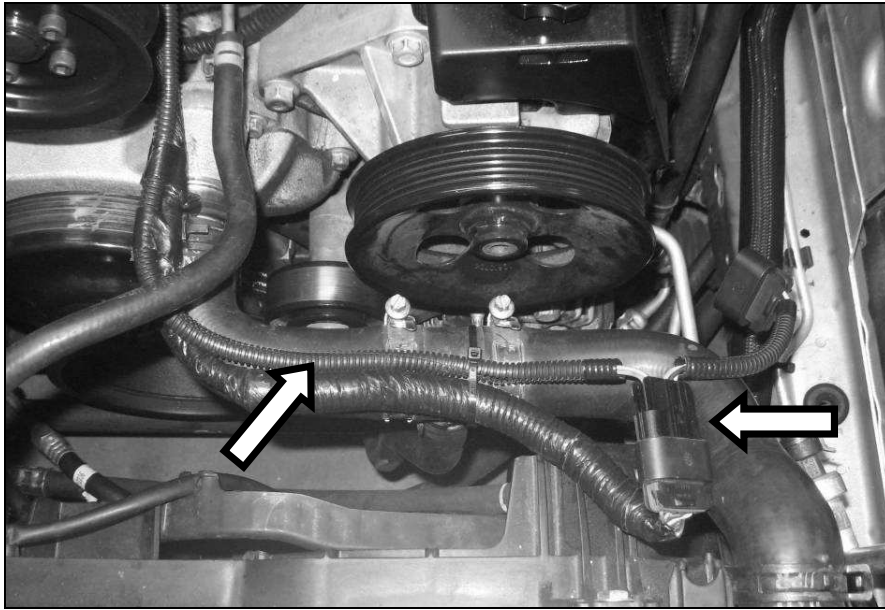

Intercooler Pump & Wiring Mounting

1. Remove the wiring retainer push pin that is located along the passenger side lower frame rail.

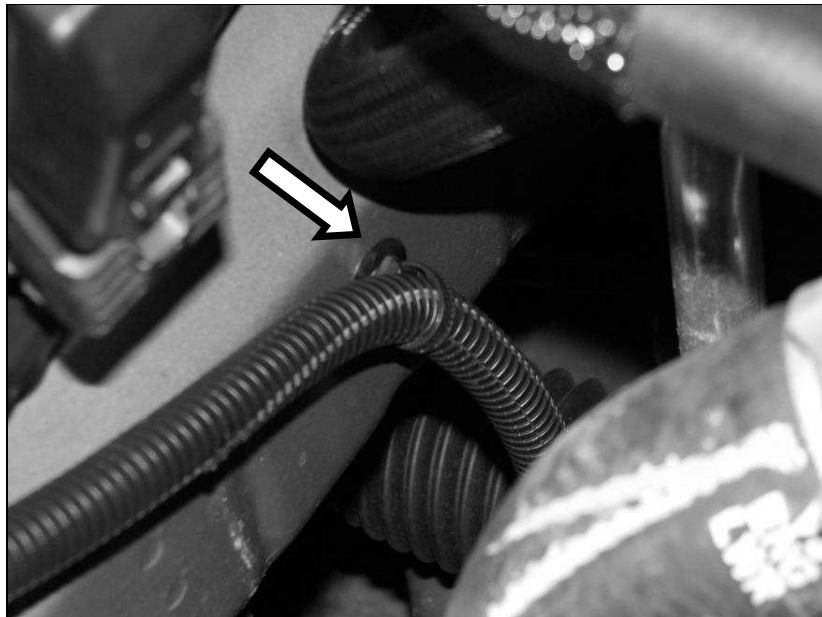



PREMIUM FUEL REQUIRED

2. Install the P-Clip (F523-036CA) using the hole in the frame rail with the supplied self tapping M8 x 27mm fastener (N802455). Both of these can be found in Hardware Kit F (HH-HWKF). Note the orientation of the P-Clip. Do not tighten.

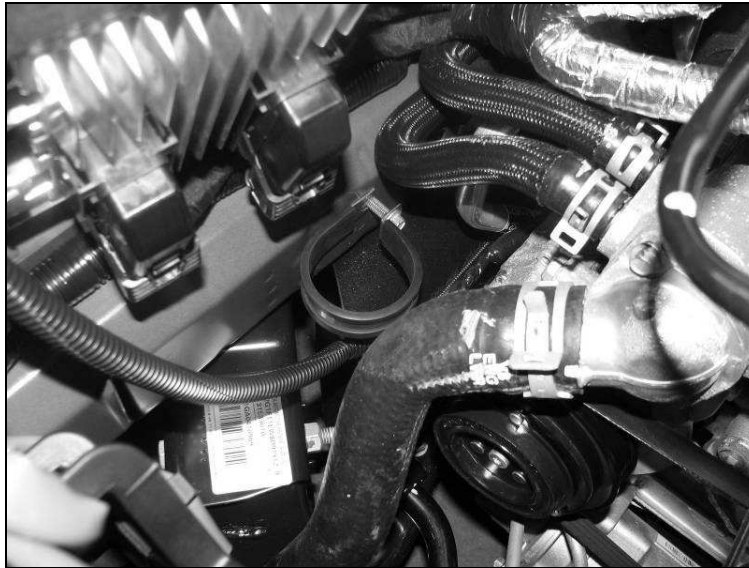

3. Insert the intercooler pump (F8YZ-8501) through the P-Clip oriented as shown. Torque to 25 Nm. NOTE: Applying some o-ring lubricant to the p-clip will aid in sliding the pump in easily.



4. Connect the I/C Pump wiring harness (HH-8W501) to the I/C Pump.
5. Route the harness up along the frame rail to the fuse box.



PREMIUM FUEL REQUIRED

6. Remove the 5 amp fuse from position #15 and place it into the lower location of the fuse jumper on the I/C Pump Wiring Harness. Place the fuse tap into Fuse Box location #15.

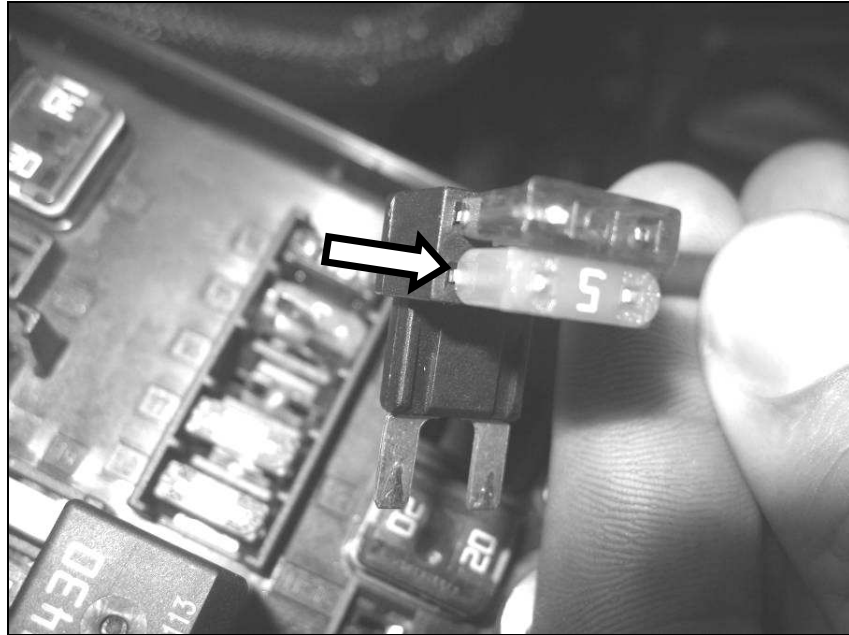

7. Secure the relay of the new harness behind the fuse box against the inner fender using the supplied self tapping fastener (R07030003). This can be found in Hardware Kit C (HH-HWKC).

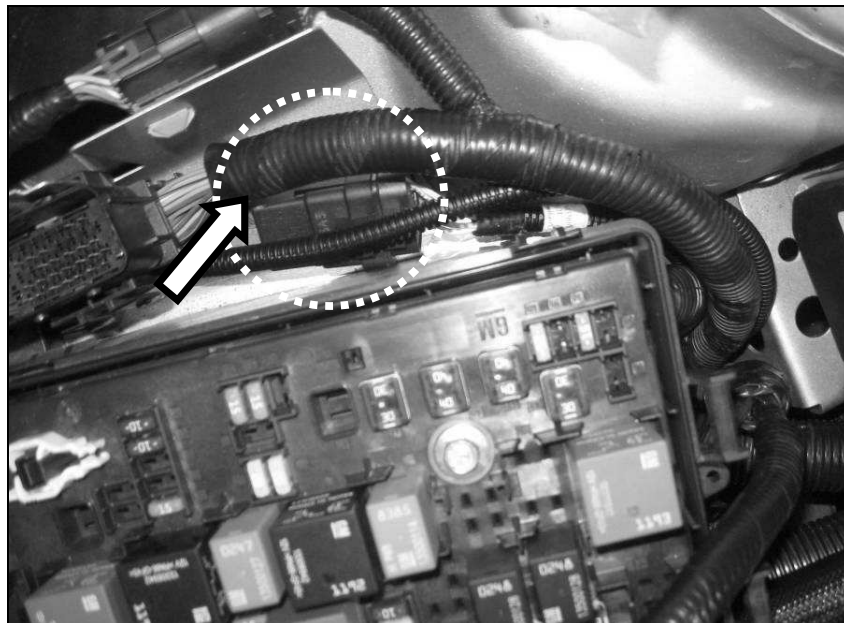



PREMIUM FUEL REQUIRED

8. Connect the Positive (+12V) eyelet on the I/C Pump Harness to the Positive post of the fuse box.



9. Connect the Negative (-12V) eyelet on the I/C Pump Harness to the Ground bolt in front of and below the ABS module utilizing the factory ground location.

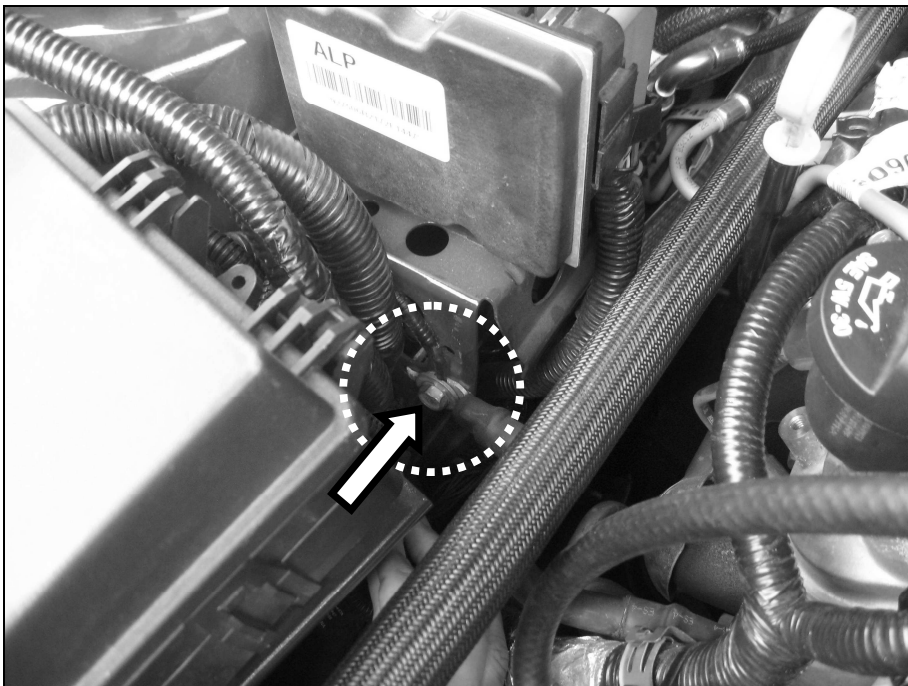



PREMIUM FUEL REQUIRED

Intercooler Radiator Assembly Mounting

1. From underneath the vehicle cut two holes into the lower close out panel using a 3" hole saw / air saw or equivalent tool for routing of the intercooler hoses. (Raise the vehicle on a lift or jack stands if available to ease installation).

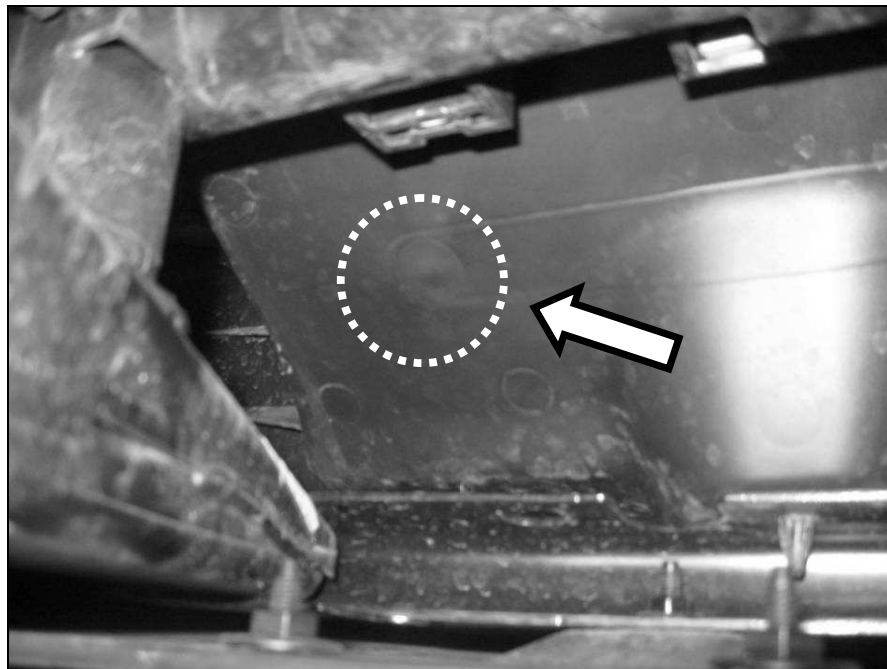
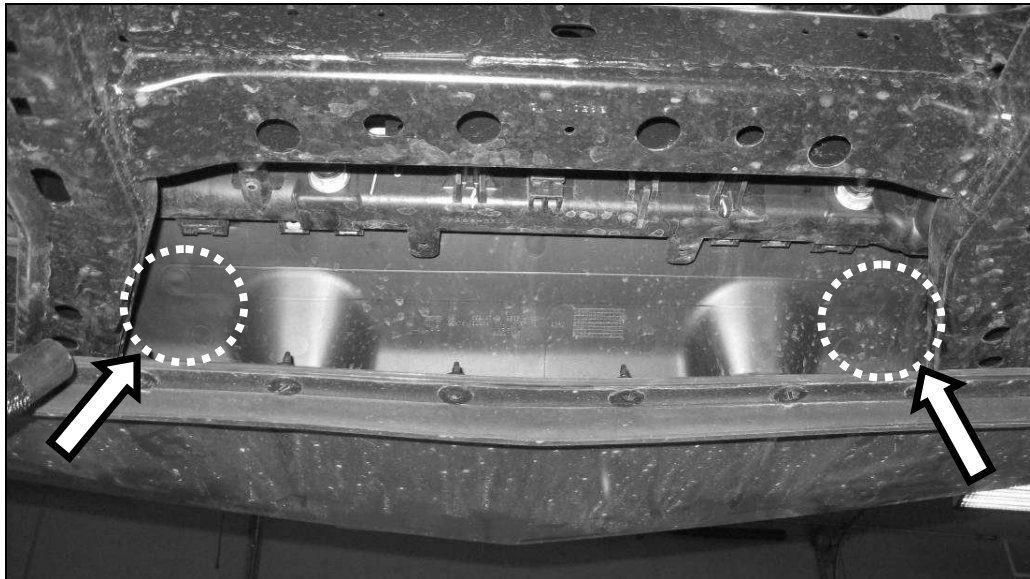

NOTE: There are circles molded into the lower close out panel that act as alignment marks for this process. You can also bring the LTR under the car and hold the fittings up against this panel and use it as a template to mark where you need to drill the access holes.



PREMIUM FUEL REQUIRED

2. Push the cooling module towards the engine and lower the new LTR (HH-8K229) in front of the A/C Condenser. Hang the new LTR on the A/C Condenser and position it so the hose fittings line up with the holes cut in the lower close out panel.

NOTE: IF YOU HAVE A CONVERTIBLE THE FRONT BRACE NEEDS TO BE PERMANENTLY REMOVED FOR ADEQUATE CLEARANCE TO INSTALL THE LTR.



3. Install the cooling module close out panel onto the clips of the radiator top tank. Install the driver side cooling module retaining bracket and secure using the factory bolt. Torque to 10 Nm.

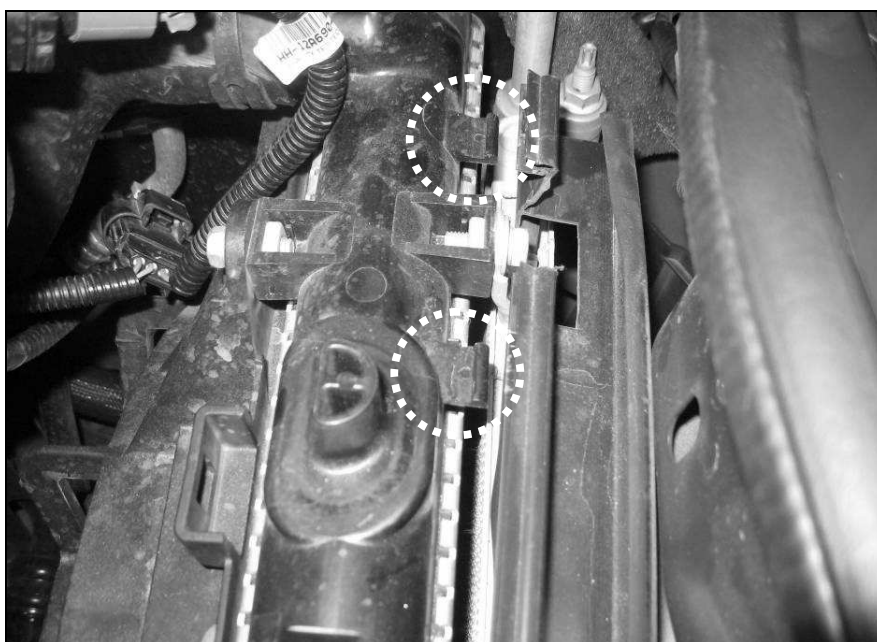



PREMIUM FUEL REQUIRED

Intercooler Degas Bottle Mounting

1. Install the J-Clip (N623332) found in Hardware Kit F (HH-HWKF) onto the detent of the fan shroud in front of the passenger side cooling module mounting post. Remove the fan shroud retaining bolt in the hole to the side of the J-Clip. **This step is ONLY required for the 2012+ Degas Bottle Mounting Bracket.**

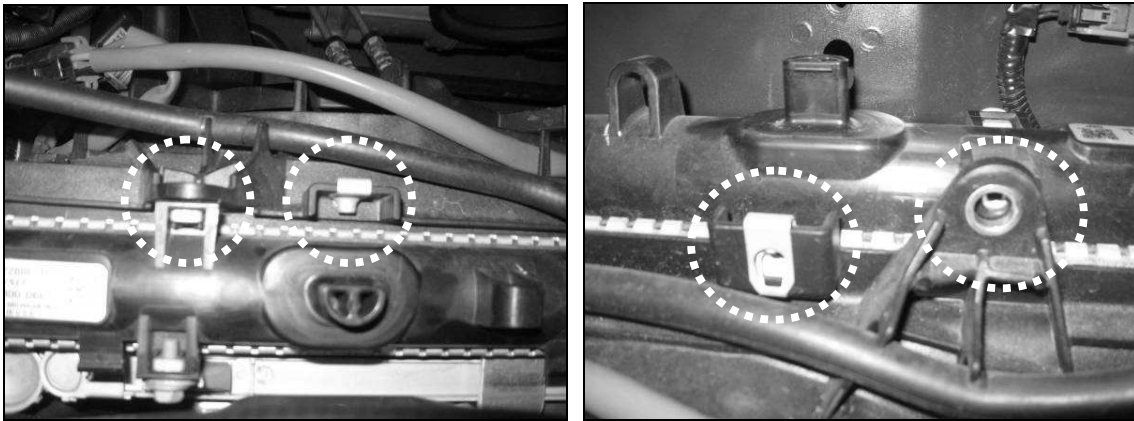

2. Install the appropriate Degas Bottle Mounting Bracket assembly into position. Secure to the fan shroud using the factory fastener (removed in previous step) and the new M6x14 bolt (N605771) into the new J-Clip. Install the bracket to the body using the take out bolt. Torque all three bolts to 10 Nm. (2012 Degas Bracket shown, 2010 similar)

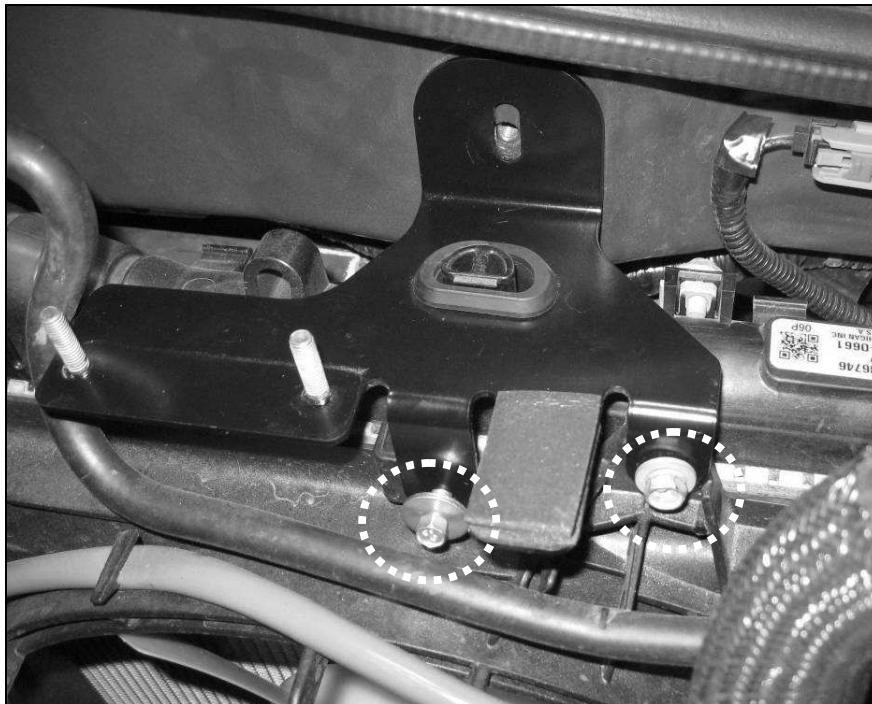



PREMIUM FUEL REQUIRED

3. Install the Degas Bottle (R07070007) onto the mounting bracket and secure using the two (2) M6 nuts (W520412) found in Hardware Kit F. Torque to 10 Nm.
4. Install the Degas Bottle Cap (9C3Z-8101) found in Hardware Kit F (HH-HWKF) at this time to keep debris out of the system.





PREMIUM FUEL REQUIRED

Intercooler Hose Routing

1. Connect the Intercooler LTR Outlet hose (HH-8D030) to the driver side turret on the rear of the intake manifold. Secure the hose using one (1) $\frac{3}{4}$ " constant tension clamp (CT19X12-BO) from Hardware Kit E (HH-HWKE). Route hose along the side of fender, behind vehicle body lines, and connect the opposite end to the outlet of the LTR on the driver side of the vehicle using one (1) $\frac{3}{4}$ " constant tension clamp (CT19X12-BO).

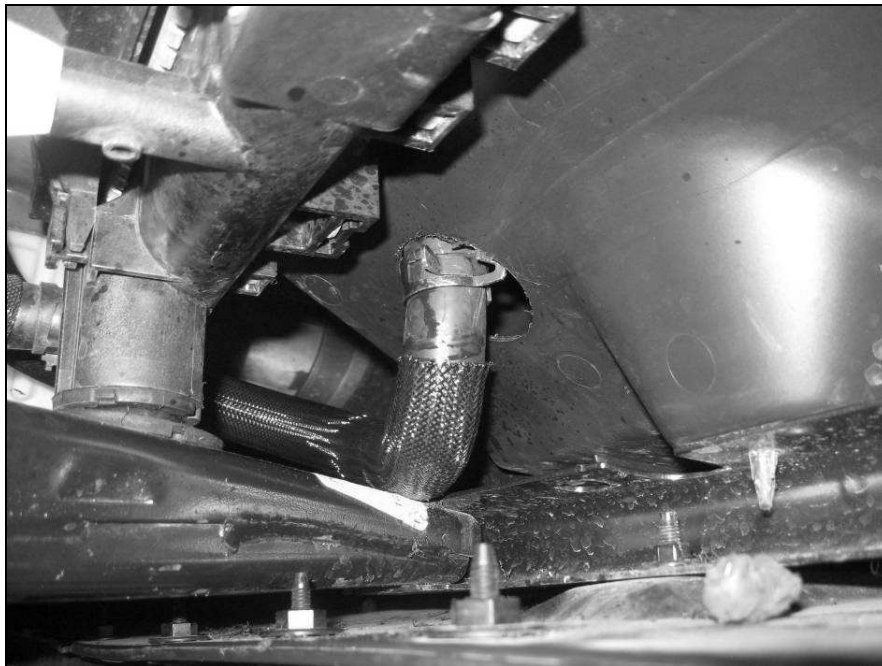



PREMIUM FUEL REQUIRED

2. Connect the I/C Pump to LTR Hose (HH-8K236) from the outlet of the I/C Pump to the inlet of the LTR. Secure the hose using one (1) $\frac{3}{4}$ " constant tension clamp (CT19X12-BO) from Hardware Kit E (HH-HWKE). Route the hose underneath the cooling module and connect to the port on the LTR using (1) $\frac{3}{4}$ " constant tension clamp (CT19X12-BO).



3. Connect the Degas Reservoir to I/C Pump Inlet Hose (HH-8D029). Secure the hose using one (1) $\frac{3}{4}$ " constant tension clamp (CT19X12-BO) from Hardware Kit E (HH-HWKE) at the pump. Route the and connect to the port on the Degas Reservoir using (1) $\frac{3}{4}$ " constant tension clamp (CT19X12-BO).

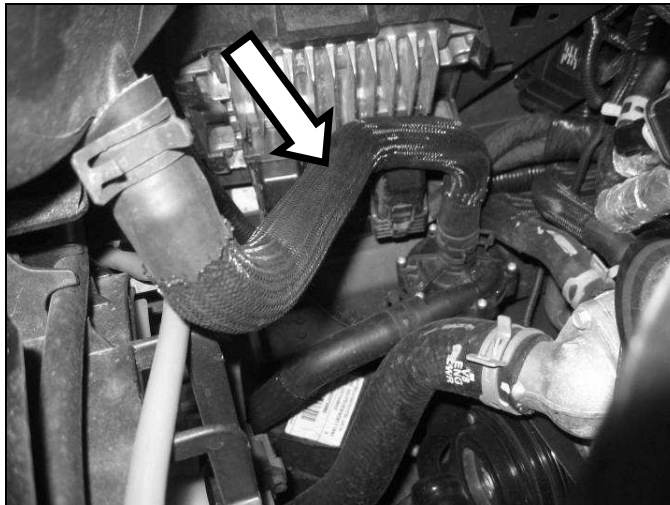



PREMIUM FUEL REQUIRED

4. Connect the CAC to Degas hose (HH-8D031) from the turret on the passenger side of the intake to the inlet port of the Degas Reservoir. Secure the hose using one (1) $\frac{3}{4}$ " constant tension clamp (CT19X12-BO) from Hardware Kit E (HH-HWKE) at the pump. Route the hose underneath the fuel supply line and connect to the port on the Degas Reservoir using (1) $\frac{3}{4}$ " constant tension clamp (CT19X12-BO).

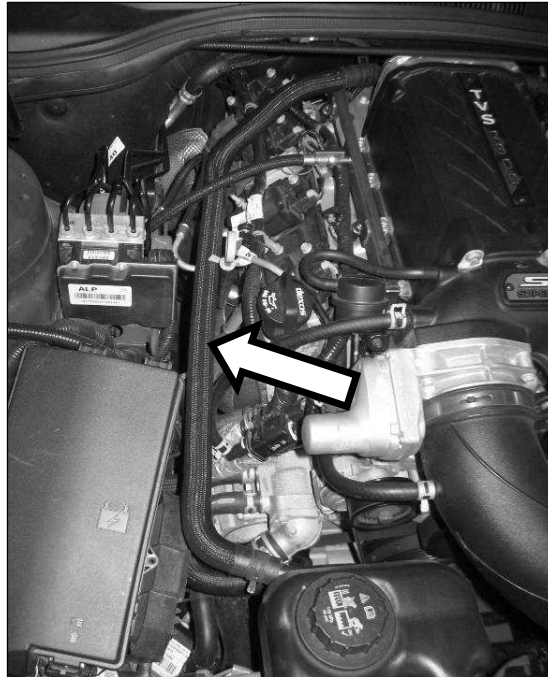

Note: Route all intercooler hoses very carefully. It is critical for intercooler performance that these hoses are not kinked once installed into the vehicle.



PREMIUM FUEL REQUIRED

Air Induction System

1. Re-install the factory airbox and secure using the fasteners that were removed.
2. Install the new Throttle Body coupler (25180042) over the end of the clean air tube (210125212).



3. Place clamps (210144126) onto each end of the new Bellows Coupler (100064010) and secure the Coupler to the opposite end of the clean air tube.





PREMIUM FUEL REQUIRED

4. Install the new Clean Air Tube assembly over the throttle body and the air box. Secure the clamps on both ends of the clean air tube. Torque to 10 Nm.

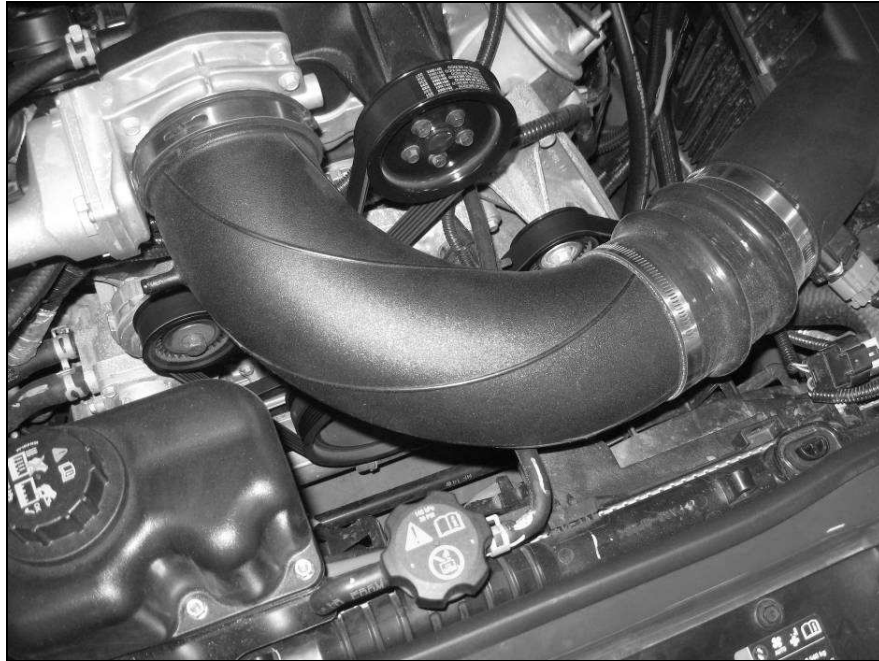

5. Connect the new MAF Harness to the MAF Sensor.

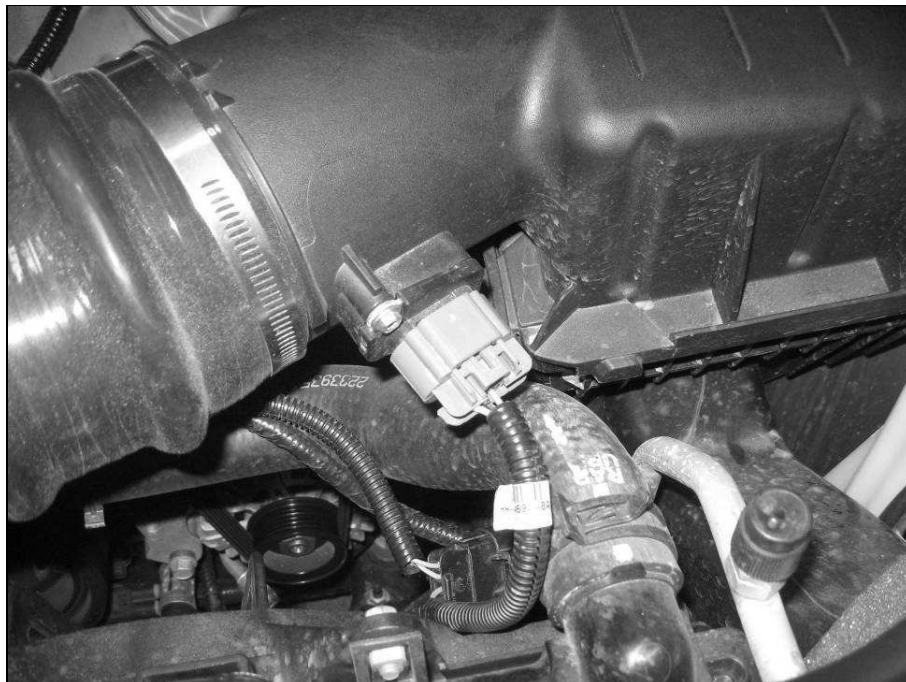



PREMIUM FUEL REQUIRED

6. Connect the PCV Fresh Air hose to the port on the Clean Air Tube.





PREMIUM FUEL REQUIRED

Vehicle Reprogramming

1. Connect the positive battery post or both battery terminals in the trunk, if disconnected at the beginning of the install.
2. Connect the Diablo inTune (SLP-1010) to the OBD port of the vehicle and turn the key to the key on position.



3. Select "Tune Vehicle" from the menu selection.

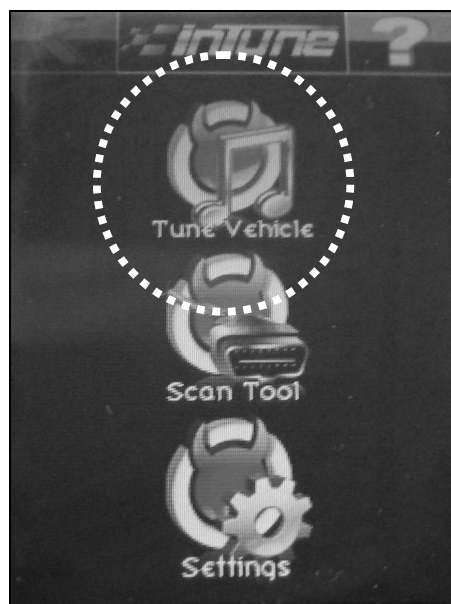



PREMIUM FUEL REQUIRED

4. Accept the Users Agreement to not use the device while driving.

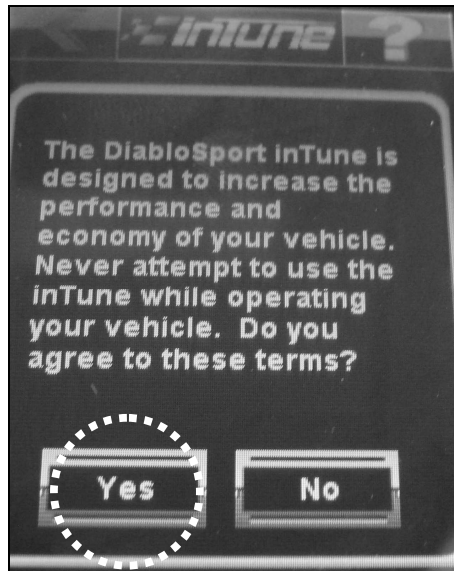

5. Select "Write Vehicle" from the display menu.

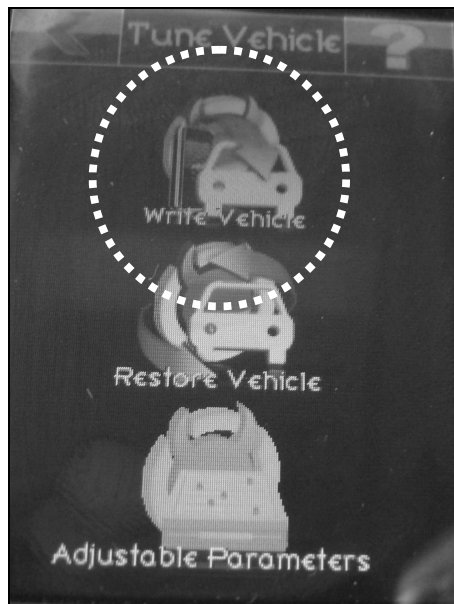



PREMIUM FUEL REQUIRED

6. If you do not have the key in the "Key On" position, you will be prompted to do this now.

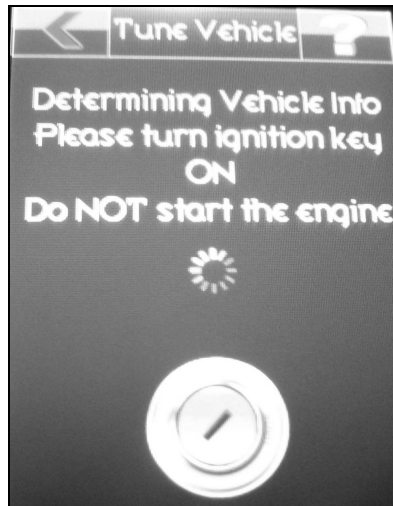

7. Select Modify Stock Tune from the display menu.

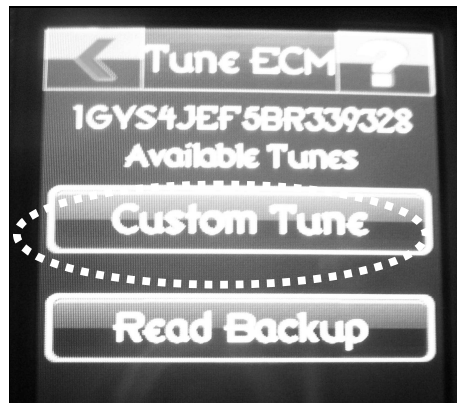

8. Select the file name that was e-mailed to you.

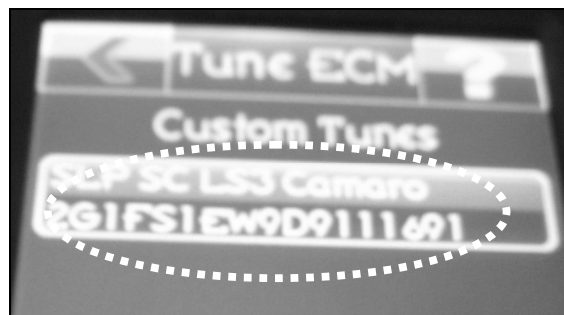



PREMIUM FUEL REQUIRED

9. Select the green check mark indicating that you want to install the ECM Custom Tune File. The VIN in the file name should match the VIN in the bottom line..

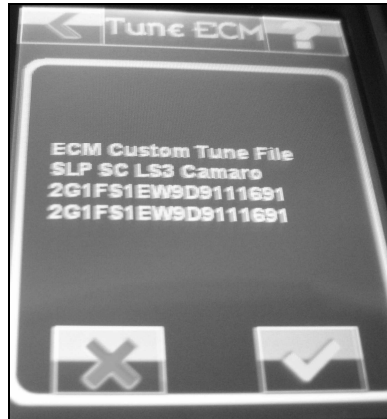

10. Select the green check mark indicating you want to proceed with the flash process.

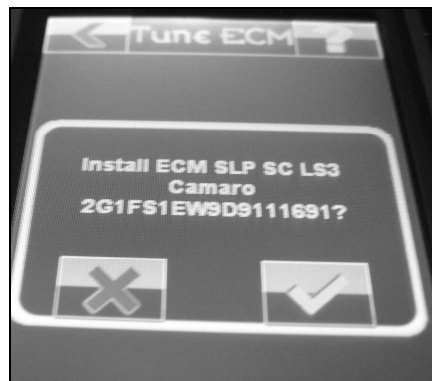

11. The inTune will now read, Building Tune and show a percentage then it will display Writing Tune and show a percentage.

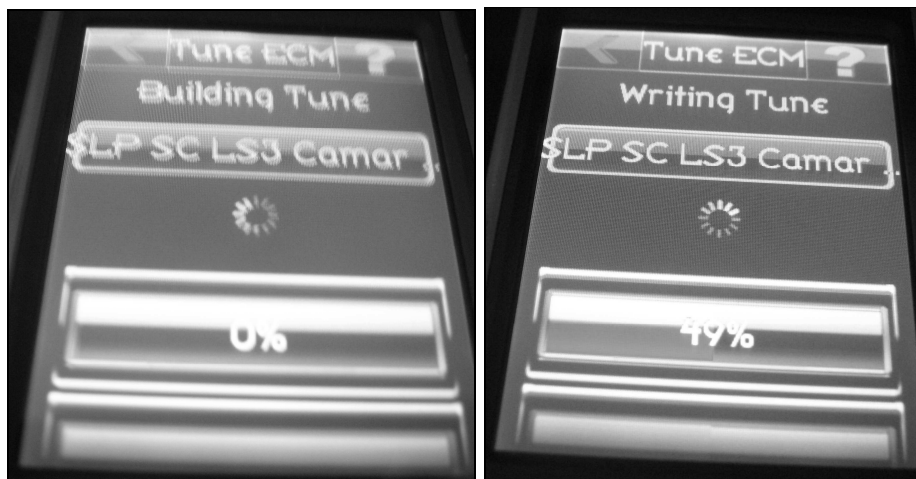



PREMIUM FUEL REQUIRED

12. Once the calibration has loaded it will show 100% and then automatically write the backup file.



13. This screen shows that the new calibration file has been loaded successfully to the vehicle. Select Continue.

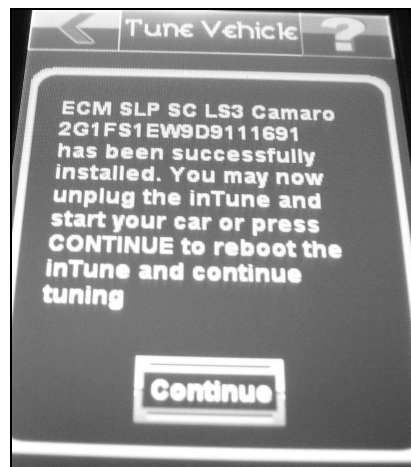

14. To confirm the calibration file, select Settings and then select Tool Info.

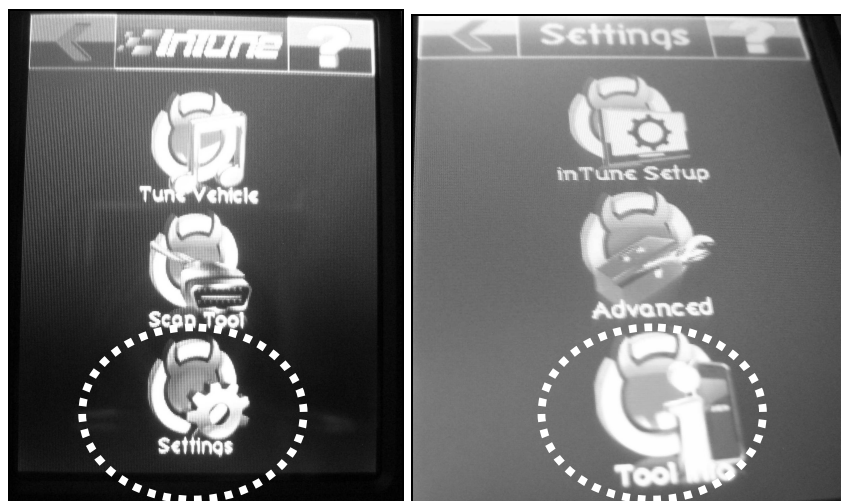



PREMIUM FUEL REQUIRED

15. Select Vehicle Info.

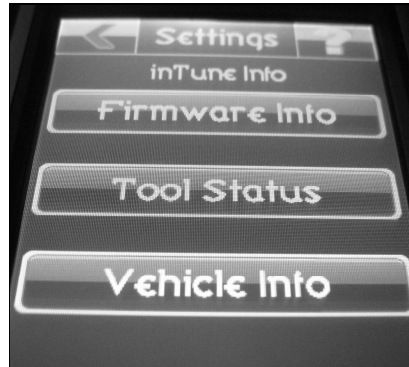

16. Key on the vehicle, if not already in Key On position.

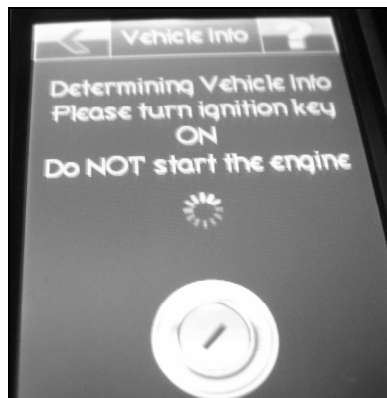

17. The 2nd line will indicate what calibration file is on the car. Confirm this matches the file name that was e-mailed to you.

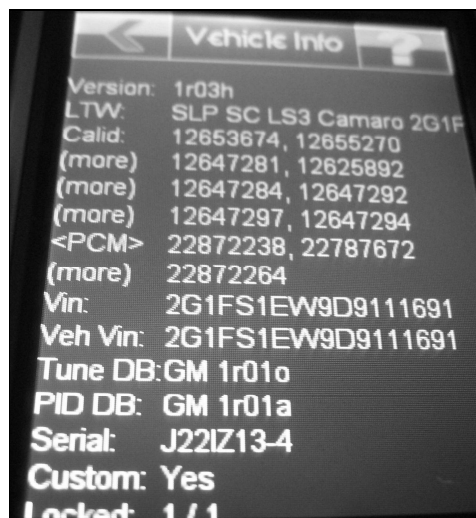

18. Unplug the inTune from the OBD port of the vehicle.



PREMIUM FUEL REQUIRED

Final Assembly

1. Fill the intercooler system through the degas bottle. The coolant should be approximately one inch below the top of the cap. Install the degas bottle cap (9C3Z-8101) and tighten when full.

Important: The coolant system can trap a large amount of air. It is very important to verify that the air is purged and that coolant is flowing properly through the systems. SLP recommends vacuum filling the system to properly evacuate the trapped air. If a vacuum fill system is not available, the plug on the top tank of the Low Temp Radiator can be removed to purge any air bubbles. Re-install plug once the coolant begins to reach the plug fitting.

2. Inspect all under hood wiring harnesses for potential interference issues. Use zip ties to safely position the harness away from any areas of concern. Ensure the supercharger bypass has adequate clearance around the actuator
3. Once the PCM has been successfully re-calibrated, start the engine and check for unusual noises, dash service lights, and unusual operation. If problems are detected, immediately stop the engine or vehicle, diagnose and repair the problem.
4. Place the appropriate Belt Routing Diagram (HH-6E072 / HH13-6E072) found in Hardware Kit G (HH-HWKG) on the underside of the hood, in the flat area on either side of the hood latch.



5. Install the EO decal opposite of the FEAD belt routing decal.
6. Place the Premium Fuel Only Decal (0102040127) beneath the fuel fill cap or on the backside of the fuel door. **With the supercharger system installed, the vehicle is no longer calibrated to run lower octane fuel. PREMIUM FUEL ONLY is REQUIRED.**



PREMIUM FUEL REQUIRED



7. Remove the adhesive covering and place the Do Not Recalibrate decal (HH-OBDCV) onto the OBD Port Cover (12146933). These can be found in Hardware Kit G (HH-HWKG).



8. Place the OBD Cover with label over the OBD Port of the vehicle. This will help eliminate the potential for accidental PCM recalibration if your vehicle goes in for service.

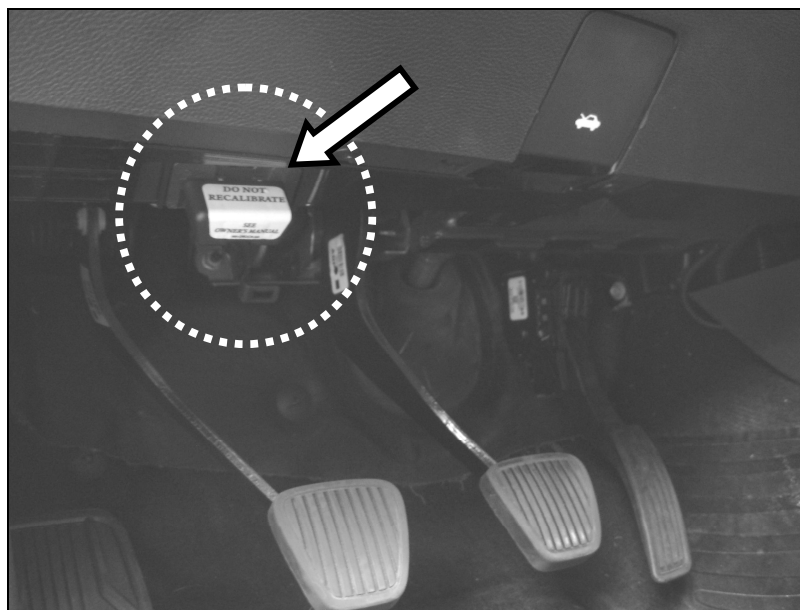



PREMIUM FUEL REQUIRED

9. Keep your Diablo inTune device in a safe location. (Glove Box of vehicle). If you are a retail shop installing this kit, please ensure the end customer gets this device. Each unit is married to the vehicle to which it is flashed and they need to be kept together for any future customer needs.
10. Congratulations, you can now go enjoy your new SLP Supercharged Camaro!!!

APPENDIX A: L99 CAMARO DOD PLATE INSTALLATION

This step is only necessary if you had the L99 DOD plate shown on page 2 of this manual.

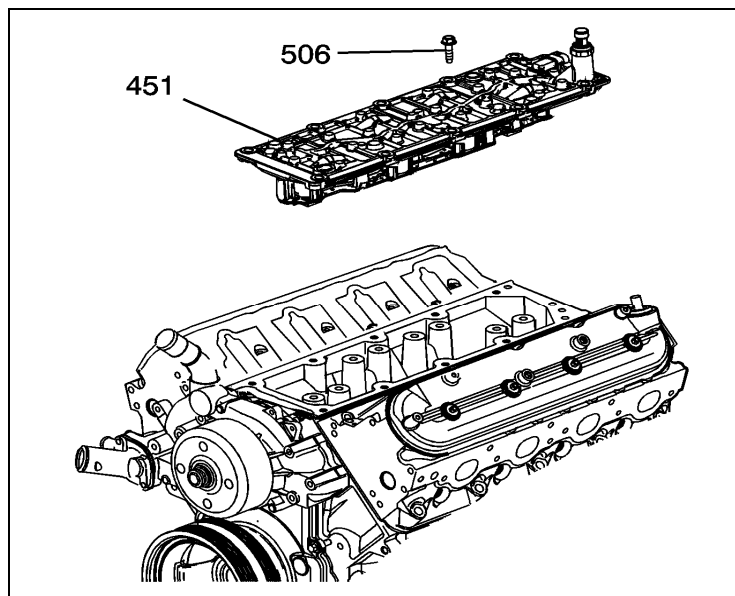

1. Install the manifold (451) with gasket.
2. Install the manifold bolts (506) and tighten to 25 Nm using a center out pattern.
3. Remove the oil pressure sensor/switch from the old cover and install into the new cover. Use thread sealer on threads and tighten the engine oil pressure sensor to 20 Nm.